

CAPACITORS



Correct Use of Chip Tantalum Capacitors

Be sure to read this before using NEC Tantalum Capacitors.

[Notes]

- Be sure to read "Notes on Using The Solid Tantalum Capacitor" (p33 - p43) and "Cautions" (p43) before commencing circuit design or using the capacitor.
- Confirm the usage conditions and rated performance of the capacitor before use.
- Ninety percent of the failure that occurs in this capacitor is caused by an increase in leakage current or short-circuiting. It is therefore important to make sufficient allowances for redundant wiring in the circuit design.

[Quality Grades]

NEC devices are classified into the following quality grades in accordance with their application (for details of the applications, see p43). **The quality grade of all devices in this document is "standard"; the devices in this document cannot be used for "special" or "specific" quality grade applications. Customers who intend to use a product or products in this document for applications other than those specified under the "standard" quality grade must contact an NEC sales representative in advance (see the reverse side of the cover for contact details).**

- **Standard:** This quality grade is intended for applications in which failure or malfunction of the device is highly unlikely to cause harm to persons or damage to property, or be the source of any negative effects or problems in the wider community.
- **Special:** This quality grade is intended for special applications that have common requirements, such as specific industrial fields. Devices with a "special" quality grade are designed, manufactured, and tested using a more stringent quality assurance program than that used for "standard" grade devices. There is a high possibility that failure or malfunction of the device when being used for applications in this category will cause harm to persons or damage to property, or create negative effects or problems in the wider community.
- **Specific:** Devices with a "specific" quality grade are designed, manufactured, and tested using a quality assurance program that is designated by the customer or that is created in accordance with the customer's specifications. There is an extremely high possibility that failure or malfunction of the device when being used for applications in this category will cause harm to persons or damage to property, or create serious problems in the wider community. Customers who use NEC's products for these "specific" applications must conclude an individual quality agreement and/or development agreement with NEC. A quality assurance program designated by the customer must also be determined in advance.

NEC offers the latest technology

<Tantalum Capacitors>



<Conductive Polymer Tantalum Capacitors>
"NeoCapacitors"



NEC has been manufacturing solid electrolyte tantalum capacitors for more than 30 years. As a result of NEC's active research and development programs, NEC capacitors offer the designer the latest technology plus outstanding performance. NEC capacitors are used extensively in industrial, commercial, entertainment, and medical electronic equipment. NEC has obtained ISO 9001 and QS9000 certificates of registration for capacitors. NEC, in response to the wave of the worldwide environment protection consciousness, developed E/SV series by eliminating lead from the terminals, and halide material and antimony from the molded resin.

The low-ESR conductive polymer tantalum capacitors are expected to meet an important market need; they are suited for DC/DC converters, video cameras, personal handy phones, etc.

TABLE OF CONTENTS

Tantalum Capacitors	4
E/SV Series Tantalum Chip Capacitors (Lead-free Type)	5
R Series Tantalum Chip Capacitors (Standard Type)	9
SV/S Series Tantalum Chip Capacitors (Miniaturized Type)	15
SV/H Series Tantalum Chip Capacitors (Higher Performance Type).....	17
SV/F Series Tantalum Chip Capacitors (Fuse Built-in Type)	20
SV/Z Series Tantalum Chip Capacitors (Low-ESR Type)	23
Tape and Reel Specifications	25
Conductive Polymer Tantalum Capacitors (NeoCapacitors)	
PS/L Series NeoCapacitors	27
Tape and Reel Specifications	31
Notes on Using the Solid Tantalum Capacitors	33
Notes on Using the Chip Tantalum Capacitors, excluding NeoCapacitors	36
Notes on Using NeoCapacitors	39

TANTALUM CAPACITORS

Description

NEC's tantalum capacitors offer the designer advanced technological design and excellent performance characteristics for filtering, bypassing, coupling, decoupling, blocking, and R C timing circuits. They are used extensively in industrial, commercial, entertainment, and medical electronic equipment.

The tantalum capacitor is inherently very reliable and there is significant evidence that this reliability improves with age—perhaps indefinitely. Capacitance loss with age and other problems often associated with liquid electrolytes are nonexistent in solid electrolyte tantalums.

A process used to further improve the reliability of tantalums is to burn them in at elevated voltages at 85°C for extended periods of time, thus eliminating high leakage and other undesirable characteristics. This process is done because solid electrolyte tantalum capacitors do not conform to the exponential distribution of time ordered failures, but instead exhibit a constantly decreasing failure rate.

If you specify NEC tantalums, you can feel confident that you are getting the best available quality, reliability, and price.

CHIP TANTALUM CAPACITORS

Conventional Type (Manganese Dioxide Type)							
Series	Operating Temperature Range (°C)	DC Rated Voltage Range (V)	Capacitance Range (μF)	Capacitance Tolerance (%)	DC Leakage Current (μA)	Tangent of Loss Angle	Features
E/SV	-55 to +125	2.5 to 35	0.47 to 680	±20	0.01 CV ⁽¹⁾ or 0.5 whichever is greater	2.5 Vdc to 10 Vdc ⁽²⁾ : 0.08 to 0.16 16 Vdc to 35 Vdc : 0.06, 0.10	Lead-free
R	-55 to +125	(Standard) 4 to 50	(Standard) 0.47 to 68	±20 ±10	0.01 CV ⁽¹⁾ or 0.5 whichever is greater	0.047 to 4.7 μF : 0.04 6.8 to 68 μF : 0.06	Standard
		(Extended) 2.5 to 35	(Extended) 0.47 to 680	±20 ±10	0.01 CV ⁽¹⁾ or 0.5 whichever is greater	2.5 Vdc to 10 Vdc ⁽³⁾ : 0.08 to 0.16 16 Vdc to 35 Vdc : 0.06, 0.10	Miniaturized
SV/S	-55 to +125	2.5 to 16	0.47 to 33	±20	0.01 CV ⁽¹⁾ or 0.5 whichever is greater	0.1, 0.2 ⁽⁴⁾	Ultra miniaturized
SV/H	-55 to +125	10 to 35	0.47 to 33	±20 ±10	0.01 CV ⁽¹⁾ or 0.5 whichever is greater	0.47 to 4.7 μF : 0.04 6.8 to 33 μF : 0.06	Higher performance
SV/F	-55 to +125	10 to 50	1 to 47	±20 ±10	0.01 CV ⁽¹⁾ or 0.5 whichever is greater	1 to 4.7 μF : 0.04 6.8 to 47 μF : 0.06	Built-in Fuse
SV/Z	-55 to +125	4 to 10	10 to 330	±20	0.01 CV ⁽¹⁾ or 0.5 whichever is greater	0.08 to 0.14 ⁽⁵⁾	Low ESR
NeoCapacitor (Conductive Polymer Type)							
PS/L	-55 to +105	4 to 10	2.2 to 470	±20	0.1 CV ⁽¹⁾ or 3, whichever is greater	0.09 to 0.50 ⁽⁶⁾	Ultra-low ESR

- Notes**
1. Product of capacitance in μF and voltage in V.
 2. Refer to Standard Ratings on page 8
 3. Refer to Standard Ratings on pages 13, 14
 4. Refer to Standard Ratings on page 16
 5. Refer to Standard Ratings on page 24
 6. Refer to Standard Ratings on pages 29, 30

E/SV Series Tantalum Chip Capacitors

DIMENSIONS [mm]

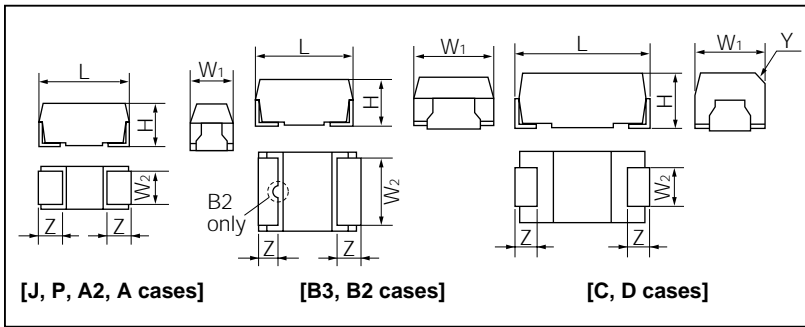

(Unit: mm)

Case Code	EIA code	L	W ₁	W ₂	H	Z	Y
J	-	1.6 ± 0.1	0.8 ± 0.1	0.6 ± 0.1	0.8 ± 0.1	0.3 ± 0.15	
P	2012	2.0 ± 0.1	1.25 ± 0.2	0.9 ± 0.2	1.1 ± 0.1	0.5 ± 0.1	
A2 (U)	3216L	3.2 ± 0.2	1.6 ± 0.2	1.2 ± 0.1	1.1 ± 0.1	0.8 ± 0.2	
A	3216H	3.2 ± 0.2	1.6 ± 0.2	1.2 ± 0.1	1.6 ± 0.2	0.8 ± 0.2	
B3 (W)	-	3.5 ± 0.2	2.8 ± 0.2	2.2 ± 0.1	1.1 ± 0.1	0.8 ± 0.2	
B2 (S)	3528	3.5 ± 0.2	2.8 ± 0.2	2.3 ± 0.1	1.9 ± 0.2	0.8 ± 0.2	
C	6032	6.0 ± 0.2	3.2 ± 0.2	2.2 ± 0.1	2.5 ± 0.2	1.3 ± 0.2	0.4 C
D	7343	7.3 ± 0.2	4.3 ± 0.2	2.4 ± 0.1	2.8 ± 0.2	1.3 ± 0.2	0.5 C

(STANDARD C-V VALUE REFERENCE BY CASE CODE)

DC Rated Voltage (Vdc) / μF	2.5	4	6.3	10	16	20	25	35
0.47					P	A2	A	A
0.68					P	A2	A	A
1.0				P	J, P	A2	A	A
1.5			P	J, P	A	A2		A
2.2			J	J, P	A2, A	A	A	B2
3.3		P	J	P, A2	A	A		B2
4.7			J, P, A	P, A2, A	A	A, B2	B2	C
6.8		J	P, A2	A	A, B3	B2		C
10	J	J, P	P, A2, A	A2, A, B2	A, B3, B2	B2	C	D
15		P	A2, A	B3	B2	C		D
22	P	P, A2, A	A, B3, B2	A, B3, B2	B2, C	C, D		D
33	P	A	A, B3	B2	C	D		
47	A	A, B3	A, B3, B2, C	B2, C	C, D	D		
68	A	B3	B2	C	D			
100	B3, B2	B3, B2	B2, C	C, D	D			
150	B2	B2	C	D				
220	B2	C	C, D	D				
330	C	C	D					
470	C, D	D	D					
680		D						

PERFORMANCE CHARACTERISTICS

Operating temperature range
 -55 to +125°C with proper voltage derating as shown in the following table.
 DC working voltage and surge voltage

Rated voltage	2.5	4	6.3	10	16	20	25	35	V	
Working	at 85°C	2.5	4	6.3	10	16	20	25	35	V
	at 125°C	1.6	2.5	4	6.3	10	13	16	22	V
Surge	at 85°C	3.3	5.2	8	13	20	26	33	46	V

Capacitance (at 20°C, 120 Hz)
 Range: 0.47 μF to 680 μF
 Tolerance: ± 20%, (±10%)
 Capacitance change with temperature
 Not to exceed -12% at -55°C, +12% at 85°C, and +15% at 125°C
 Tangent of loss angle (at 20°C, 120 Hz) (Standard)
 0.047 μF to 4.7 μF: less than 0.04
 6.8 μF to 68 μF: less than 0.06
 (Extended) (1)
 2.5 Vdc to 10 Vdc: less than 0.08
 16 Vdc to 35 Vdc: less than 0.06
 DC leakage current (at 20°C)
 0.01 C·V(2) μA or 0.5 μA, whichever is greater
 Damp heat (90 to 95% RH at 40°C, 56 days (1344 h))
 Capacitance change: ±5% (±12%) (3)
 Tangent of loss angle: 150% of initial requirements

DC leakage current: initial requirements
 Endurance (at 85°C, DC rated voltage, 2000 h)
 Capacitance change: ±10% (±12%) (3)
 Tangent of loss angle: initial requirements
 DC leakage current: 125% of initial requirements

Resistance to soldering heat (solder reflow at 260°C, 10 s. or solder dip at 260°C, 5 s.)
 Capacitance change: +5% (+12%) (3)
 Leakage current: initial requirements
 Tangent of loss angle: initial requirements

NEC obtained IEC Qualification Approval on R Series Standard Ratings in September 1987.

- Refer to standard ratings for tangent of loss angle of the following items:
 4 V/22 μF, 6.3 V/15 μF products in A2 case.
 2.5 V/47 μF, 68 μF, 4 V/33 μF, 47 μF, 6.3 V/22 μF, 33 μF, 47 μF, 10 V/22 μF, 16 V/10 μF products in A case.
 2.5 V/100 μF, 4 V/47 μF, 68 μF, 100 μF, 6.3 V/22 μF, 33 μF, 47 μF, 10 V/15 μF, 22 μF, 16 V/10 μF products in B3 case.
 2.5 V/150 μF, 220 μF, 4 V/100 μF, 150 μF, 6.3 V/68 μF, 100 μF products in B2 case.
 2.5 V/470 μF, 4 V/470 μF, 680 μF, 6.3 V/220 μF, 330 μF, 470 μF, 10 V/150 μF, 220 μF, 16 V/100 μF products in D case.
- Product of capacitance in μF and voltage in V.
- Capacitance change of ± 12% applies to
 4 V/22 μF, 6.3 V/6.8 μF to 15 μF, 10 V/3.3 μF to 10 μF, 16 V/2.2 μF products in A2 case;
 2.5 V/47 μF, 68 μF, 4 V/22 μF to 47 μF, 6.3 V/10 μF to 47 μF, 10 V/4.7 μF to 22 μF, 16 V/3.3 μF to 6.8 μF, 20 V/2.2 μF to 4.7 μF, 25 V/2.2 μF, 35 V/1 μF, 1.5 μF products in A case;
 2.5 V/100 μF to 150 μF, 4 V/100 μF, 6.3 V/68 μF, 100 μF products in B2 case;
 2.5 V/470 μF, 4 V/220 μF to 330 μF, 6.3 V/100 μF, 10 V/68 μF, 16 V/47 μF products in C case;
 2.5 V/470 μF, 4 V/470 μF, 680 μF, 6.3 V/220 μF, 330 μF, 470 μF, 10 V/150 μF, 220 μF, 16 V/100 μF products in D case.
 Capacitance change of ±15% applies to all products with the B3 case.

See pages 25 and 26 for taping specifications.

Markings

The standard marking shows capacitance, DC rated voltage, and polarity.

[J case]

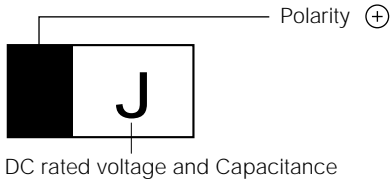

[J case Marking Code]

μF \ U _R	2.5 V	4 V	6.3 V	10 V	16 V
1					⊖
1.5				V	
2.2			Γ	<	
3.3			↵		
4.7		⊖	J		
6.8		G			
10	e				

[P case]

up to 6.8 μF

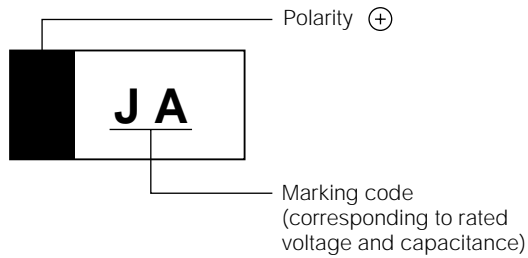

[P case Marking Code]

DC Rated Voltage (Vdc) \ μF	2.5	4	6.3	10	16
0.47					CS
0.68					CW
1				AA	CA
1.5			JE	AE	
2.2				AJ	
3.3		GN		AN	
4.7			JS	AS	
6.8			JW		
10		GĀ	JĀ		
15		GĒ			
22	eĴ	GĴ			
33	eN				

over 10 μF

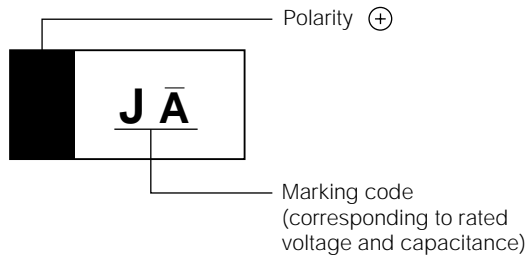

[A2, A case]

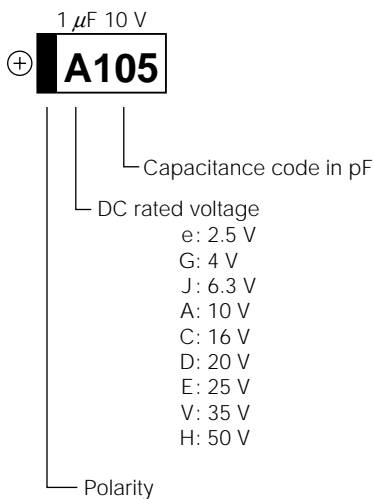

[B3, B2 case]

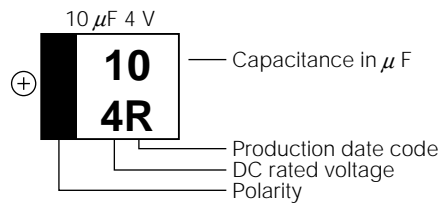

[Marking of production date code]

Y \ M	Jan.	Feb.	Mar.	Apr.	May	Jun.	Jul.	Aug.	Sep.	Oct.	Nov.	Dec.
2001	A	B	C	D	E	F	G	H	J	K	L	M
2002	N	P	Q	R	S	T	U	V	W	X	Y	Z
2003	a	b	c	d	e	f	g	h	j	k	l	m
2004	n	p	q	r	s	t	u	v	w	x	y	z

Note: Production date code will repeat beginning in 2005.

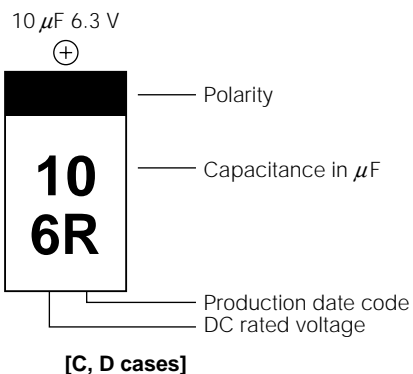

[Marking of production date code]

Y \ M	Jan.	Feb.	Mar.	Apr.	May	Jun.	Jul.	Aug.	Sep.	Oct.	Nov.	Dec.
2001	A	B	C	D	E	F	G	H	J	K	L	M
2002	N	P	Q	R	S	T	U	V	W	X	Y	Z
2003	a	b	c	d	e	f	g	h	j	k	l	m
2004	n	p	q	r	s	t	u	v	w	x	y	z

Note: Production date code will repeat beginning in 2005.

PART NUMBER SYSTEM

Bulk

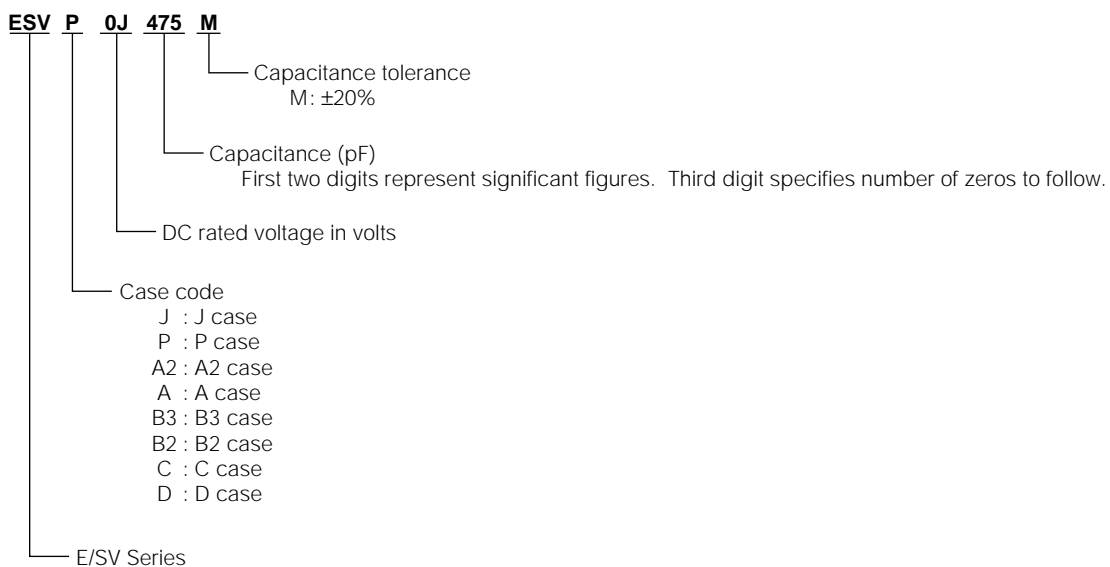

Tape and Reel

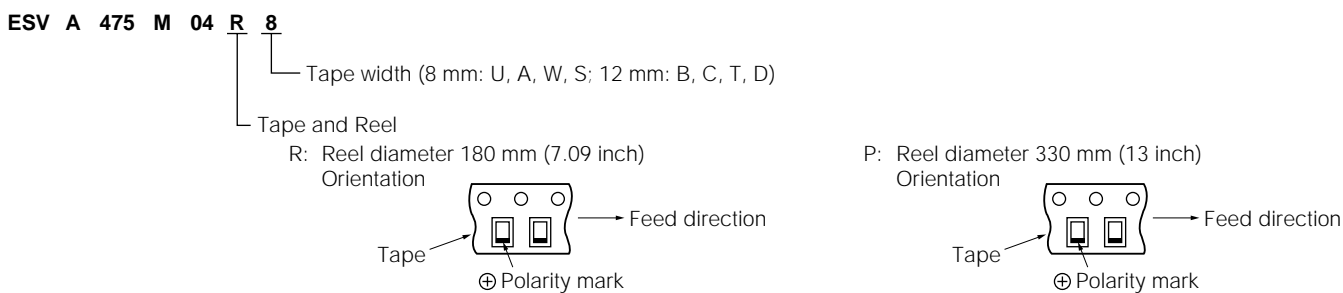

STANDARD RATINGS

Part Number	Capacitance (μF)	Case Code	DC Leakage Current (μA)	Tangent of Loss Angle
2.5 V Rating				
ESVJ0E106M	10	J	0.5	0.2
ESVP0E226M	22	P	0.5	0.2
ESVP0E336M	33	P	0.8	0.2
ESVA0E476M	47	A	1.1	0.12
ESVA0E686M	68	A	1.7	0.18
ESVB30E107M	100	B3	2.5	0.18
ESVB20E107M	100	B2	2.5	0.08
ESVB20E157M	150	B2	3.7	0.16
ESVB20E227M	220	B2	5.5	0.18
ESVC0E337M	330	C	8.2	0.16
ESVC0E477M	470	C	11.7	0.18
ESVD0E477M	470	D	11.7	0.14
4 V Rating				
ESVP0G335M	3.3	P	0.5	0.2
ESVJ0G685M	6.8	J	0.5	0.2
ESVJ0G106M	10	J	0.5	0.2
ESVP0G106M	10	P	0.5	0.2
ESVP0G156M	15	P	0.6	0.2
ESVP0G226M	22	P	0.8	0.2
ESVP0G226M	22	P	0.8	0.12
ESVA20G226M	22	A2	0.8	0.08
ESVA0G336M	33	A	1.3	0.1
ESVA0G476M	47	A	1.8	0.12
ESVA0G476M	47	A	1.8	0.12
ESVB30G686M	68	B3	2.7	0.15
ESVB30G107M	100	B3	4	0.2
ESVB20G107M	100	B2	4	0.12
ESVB20G157M	150	B2	6	0.18
ESVC0G227M	220	C	8.8	0.12
ESVC0G337M	330	C	13.2	0.14
ESVD0G477M	470	D	18.8	0.16
ESVD0G687M	680	D	27.2	0.24
6.3 V Rating				
ESVP0J155M	1.5	P	0.5	0.1
ESVJ0J225M	2.2	J	0.5	0.2
ESVJ0J335M	3.3	J	0.5	0.2
ESVJ0J475M	4.7	J	0.5	0.2
ESVP0J475M	4.7	P	0.5	0.2
ESVA0J475M	4.7	A	0.5	0.08
ESVP0J685M	6.8	P	0.5	0.2
ESVA20J685M	6.8	A2	0.5	0.08
ESVP0J106M	10	P	0.6	0.2
ESVA20J106M	10	A2	0.6	0.08
ESVA0J106M	10	A	0.6	0.08
ESVA20J156M	15	A2	0.9	0.12
ESVA0J156M	15	A	0.9	0.08
ESVA0J226M	22	A	1.3	0.1
ESVB30J226M	22	B3	1.3	0.08
ESVB20J226M	22	B2	1.3	0.08
ESVA0J336M	33	A	2	0.12
ESVB30J336M	33	B3	2	0.12
ESVA0J476M	47	A	3	0.12
ESVB30J476M	47	B3	2.9	0.12
ESVB20J476M	47	B2	3	0.08
ESVC0J476M	47	C	3	0.08
ESVB20J676M	67	B2	4.2	0.1
ESVB20J107M	100	B2	6.3	0.12
ESVC0J107M	100	C	6.3	0.1
ESVC0J157M	150	C	9.4	0.1
ESVC0J227M	220	C	13.8	0.14
ESVD0J227M	220	D	13.8	0.12
ESVD0J337M	330	D	20.7	0.14
ESVD0J477M	470	D	29.7	0.2
10 V Rating				
ESVP1A105M	1	P	0.5	0.1
ESVJ1A155M	1.5	J	0.5	0.2
ESVP1A155M	1.5	P	0.5	0.2
ESVJ1A225M	2.2	J	0.5	0.2
ESVP1A225M	2.2	P	0.5	0.2
ESVP1A335M	3.3	P	0.5	0.2
ESVA21A335M	3.3	A2	0.5	0.08
ESVP1A475M	4.7	P	0.5	0.2
ESVA21A475M	4.7	A2	0.5	0.08
ESVA1A475M	4.7	A	0.5	0.08
ESVA1A685M	6.8	A	0.6	0.08
ESVA21A106M	10	A2	1	0.08
ESVA1A106M	10	A	1	0.08
ESVB21A106M	10	B2	1	0.08

Part Number	Capacitance (μF)	Case Code	DC Leakage Current (μA)	Tangent of Loss Angle
10 V Rating				
ESVB31A156M	15	B3	1.5	0.12
ESVA1A226M	22	A	2.2	0.12
ESVB21A226M	22	B2	2.2	0.12
ESVB21A226M	22	B2	2.2	0.08
ESVB21A336M	33	B2	3.3	0.08
ESVB21A476M	47	B2	4.7	0.08
ESVC1A476M	47	C	4.7	0.08
ESVC1A686M	68	C	6.8	0.08
ESVC1A107M	100	C	10	0.1
ESVD1A107M	100	D	10	0.08
ESVD1A157M	150	D	15	0.1
ESVD1A227M	220	D	22	0.12
16 V Rating				
ESVP1C474M	0.47	P	0.5	0.1
ESVP1C684M	0.68	P	0.5	0.1
ESVJ1C105M	1	J	0.5	0.1
ESVP1C105M	1	P	0.5	0.1
ESVA1C155M	1.5	A	0.5	0.04
ESVA21C225M	2.2	A2	0.5	0.06
ESVA1C225M	2.2	A	0.5	0.06
ESVA1C335M	3.3	A	0.5	0.06
ESVA1C475M	4.7	A	0.7	0.06
ESVA1C685M	6.8	A	1	0.06
ESVB31C685M	6.8	B3	1	0.06
ESVA1C106M	10	A	1.6	0.08
ESVB31C106M	10	B3	1.6	0.08
ESVB21C106M	10	B2	1.6	0.08
ESVB21C156M	15	B2	2.4	0.06
ESVB21C226M	22	B2	3.5	0.08
ESVC1C226M	22	C	3.5	0.06
ESVC1C336M	33	C	5.2	0.06
ESVC1C476M	47	C	7.5	0.06
ESVD1C476M	47	D	7.5	0.08
ESVD1C686M	68	D	10.8	0.06
ESVD1C107M	100	D	16	0.1
20 V Rating				
ESVA21D474M	0.47	A2	0.5	0.06
ESVA21D684M	0.68	A2	0.5	0.06
ESVA21D105M	1	A2	0.5	0.06
ESVA21D155M	1.5	A2	0.5	0.06
ESVA1D225M	2.2	A	0.5	0.06
ESVA1D335M	3.3	A	0.6	0.06
ESVA1D475M	4.7	A	0.9	0.06
ESVB21D475M	4.7	B2	0.9	0.06
ESVB21D685M	6.8	B2	1.3	0.06
ESVB21D106M	10	B2	2	0.06
ESVC1D156M	15	C	3	0.06
ESVC1D226M	22	C	4.4	0.06
ESVD1D226M	22	D	4.4	0.06
ESVD1D336M	33	D	6.6	0.06
ESVD1D476M	47	D	9.4	0.06
25 V Rating				
ESVA1E474M	0.47	A	0.5	0.04
ESVA1E684M	0.68	A	0.5	0.06
ESVA1E105M	1	A	0.5	0.06
ESVA1E225M	2.2	A	0.5	0.06
ESVB21E475M	4.7	B2	1.1	0.06
ESVC1E106M	10	C	2.5	0.06
ESVD1E226M	22	D	5.5	0.06
35 V Rating				
ESVA1V474M	0.47	A	0.5	0.06
ESVA1V684M	0.68	A	0.5	0.06
ESVA1V105M	1	A	0.5	0.06
ESVA1V155M	1.5	A	0.5	0.06
ESVB21V225M	2.2	B2	0.7	0.06
ESVB21V335M	3.3	B2	1.1	0.06
ESVC1V475M	4.7	C	1.6	0.06
ESVC1V685M	6.8	C	2.3	0.06
ESVD1V106M	10	D	3.5	0.06
ESVD1V156M	15	D	5.2	0.06

Notes:

Part numbers are for ±20% capacitance tolerance.

R Series Tantalum Chip Capacitors

DIMENSIONS [mm]

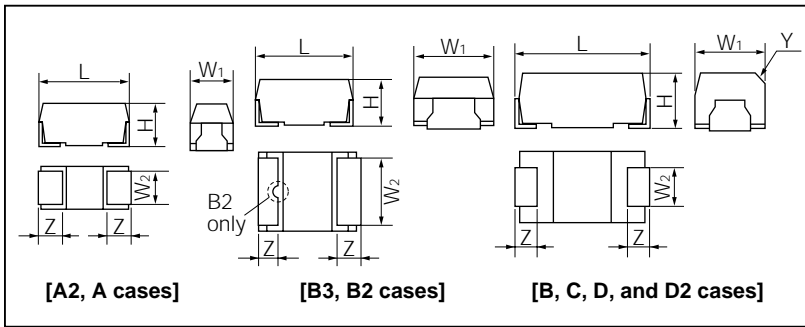

(Unit: mm)

Case Code	EIA code	L	W ₁	W ₂	H	Z	Y
A2 (U)	3216L	3.2 ± 0.2	1.6 ± 0.2	1.2 ± 0.1	1.1 ± 0.1	0.8 ± 0.2	
A	3216H	3.2 ± 0.2	1.6 ± 0.2	1.2 ± 0.1	1.6 ± 0.2	0.8 ± 0.2	
B3 (W)	—	3.5 ± 0.2	2.8 ± 0.2	2.2 ± 0.1	1.1 ± 0.1	0.8 ± 0.2	
B2 (S)	3528	3.5 ± 0.2	2.8 ± 0.2	2.3 ± 0.1	1.9 ± 0.2	0.8 ± 0.2	
B	—	4.7 ± 0.2	2.6 ± 0.2	1.4 ± 0.1	2.1 ± 0.2	0.8 ± 0.2	0.4 C
C	6032	6.0 ± 0.2	3.2 ± 0.2	2.2 ± 0.1	2.5 ± 0.2	1.3 ± 0.2	0.4 C
D2 (T)	5846	5.8 ± 0.2	4.6 ± 0.2	2.4 ± 0.1	3.2 ± 0.2	1.3 ± 0.2	
D	7343	7.3 ± 0.2	4.3 ± 0.2	2.4 ± 0.1	2.8 ± 0.2	1.3 ± 0.2	0.5 C

(STANDARD C-V VALUE REFERENCE BY CASE CODE)

DC Rated Voltage (Vdc) / μF	4	6.3	10	16	20	25	35	50
0.47						A	B2, B	B2
0.68					A		B2, B	C
1.0				A			B2, B	C
1.5			A	A		B2, B	C	C
2.2		A	A		B2, B		C	D
3.3	A	A		B2, B		C	C, D	D, D2
4.7	A		B2, B		C	C	D2, D	D
6.8		B2, B		C	C	D2, D	D2, D	
10	B2, B		C	C	D2, D	D2, D		
15		C	C	D2, D	D2, D			
22	C	C	D2, D	D2, D				
33	C	D2, D	D2, D					
47	D2, D	D2, D						
68	D2, D							

PERFORMANCE CHARACTERISTICS

Operating temperature range
 -55 to +125°C with proper voltage derating as shown in the following table.

DC working voltage and surge voltage

Rated voltage	2.5	4	6.3	10	16	20	25	35	50	V
Working	at 85°C	2.5	4	6.3	10	16	20	25	35	50
	at 125°C	1.6	2.5	4	6.3	10	13	16	22	32
Surge	at 85°C	3.3	5.2	8	13	20	26	33	46	65

Capacitance (at 20°C, 120 Hz)

Range: 0.47 μF to 680 μF

Tolerance: ± 20%, (±10%)

Capacitance change with temperature

Not to exceed -12% at -55°C, +12% at 85°C, and +15% at 125°C

Tangent of loss angle (at 20°C, 120 Hz)

(Standard)

0.047 μF to 4.7 μF: less than 0.04

6.8 μF to 68 μF: less than 0.06

(Extended) (1)

2.5 Vdc to 10 Vdc: less than 0.08

16 Vdc to 35 Vdc: less than 0.06

DC leakage current (at 20°C)

0.01 C·V⁽²⁾ μA or 0.5 μA, whichever is greater

Damp heat (90 to 95% RH at 40°C, 56 days (1344 h))

Capacitance change: ±5% (±12%) (3)

Tangent of loss angle: 150% of initial requirements

DC leakage current: initial requirements

Endurance (at 85°C, DC rated voltage, 2000 h)

Capacitance change: ±10% (±12%) (3)

Tangent of loss angle: initial requirements

DC leakage current: 125% of initial requirements

Resistance to soldering heat

(solder reflow at 260°C, 10 s.

or solder dip at 260°C, 5 s.)

Capacitance change: +5% (+12%) (3)

Leakage current: initial requirements

Tangent of loss angle: initial requirements

NEC obtained IEC Qualification Approval on R Series Standard Ratings in September 1987.

1. Refer to standard ratings for tangent of loss angle of the following items:

2.5 V/15 μF, 22 μF, 4 V/10 μF, 15 μF, 22 μF, 6.3 V/15 μF products in A2 case.

2.5 V/47 μF, 68 μF, 4 V/33 μF, 47 μF, 6.3 V/22 μF, 33 μF, 47 μF, 10 V/22 μF, 16 V/10 μF products in A case.

2.5 V/47 μF, 68 μF, 100 μF, 4 V/33 μF, 47 μF, 68 μF, 100 μF, 6.3 V/22 μF, 33 μF, 47 μF, 10 V/15 μF, 22 μF, 16 V/10 μF products in B3 case.

2.5 V/150 μF, 220 μF, 4 V/100 μF, 150 μF, 6.3 V/68 μF, 100 μF products in B2 case.

2.5 V/220 μF, 470 μF, 4 V/150 μF, 220 μF, 330 μF, 6.3 V/100 μF, 150 μF, 220 μF products in C case.

2.5 V/330 μF, 4 V/220 μF, 6.3 V/150 μF, 10 V/100 μF products in D2 case.

2.5 V/470 μF, 4 V/330 μF, 470 μF, 680 μF, 6.3 V/220 μF, 330 μF, 470 μF, 10 V/150 μF, 220 μF, 16 V/100 μF products in D case.

2. Product of capacitance in μF and voltage in V.

3. Capacitance change of ± 12% applies to

2.5 V/4.7 μF to 22 μF, 4 V/4.7 μF to 22 μF, 6.3 V/3.3 μF to 15 μF, 10 V/2.2 μF to 10 μF, 16 V/1.5 μF, 2.2 μF, 20 V/1 μF, 1.5 μF products in A2 case;

2.5 V/15 μF to 68 μF, 4 V/10 μF to 47 μF, 6.3 V/6.8 μF to 47 μF, 10 V/4.7 μF to 22 μF, 16 V/3.3 μF to 6.8 μF, 20 V/2.2 μF to 4.7 μF, 25 V/1.5 μF, 2.2 μF, 35 V/1 μF, 1.5 μF products in A case;

2.5 V/33 μF to 150 μF, 4 V/100 μF, 6.3 V/68 μF, 100 μF, 10 V/4.7 μF products in B2 case;

(R SERIES EXTENDED C-V VALUE REFERENCE BY CASE CODE)

DC Rated Voltage μF	2.5	4	6.3	10	16	20	25	35
0.47						A2		A
0.68					A2	A2	A	A
1.0				A2	A2	A2, A	A	A
1.5			A2	A2	A2	A2, A	A	A, B2, B
2.2		A2	A2	A2	A2, A	A	A, B2	B2, B
3.3		A2	A2	A2, A	A	A, B2	B2, B	B2
4.7	A2	A2	A2, A	A2, A	A, B2	A, B2, B	B2	C
6.8	A2	A2, A	A2, A	A, B2	A, B3, B2, B	B2	C	C
10	A2	A2, A	A2, A, B2	A2, A, B3, B2, B	A, B3, B2	B2, C	C	D2, D
15	A2, A	A2, A, B2	A2, A, B3, B2, B	B3, B2	B2, C	C	D2, D	D
22	A2, A	A2, A, B3, B2, B	A, B3, B2	A, B3, B2, C	B2, C	C, D2, D	D	
33	A, B3, B2	A, B3, B2	A, B3, B2, C	B2, C	C, D2, D	D2, D		
47	A, B3, B2	A, B3, B2, C	A, B3, B2, C	B2, C, D2, D	C, D2, D	D		
68	A, B3, B2	B3, B2, C	B2, C, D2, D	C, D2, D	D			
100	B3, B2	B3, B2, C, D2, D	B2, C, D2, D	C, D2, D	D			
150	B2	C, D2, D	C, D2, D	D				
220	B2, C	C, D2, D	C, D	D				
330	D2	C, D	D					
470	C, D	D	D					
680		D						

2.5 V/220 μF, 470 μF, 4 V/150 μF to 330 μF, 6.3 V/100 μF, 10 V/68 μF, 16 V/47 μF products in C case;
 2.5 V/330 μF, 4 V/220 μF, 6.3 V/150 μF, 10 V/100 μF products in D2 case;
 2.5 V/470 μF, 4 V/330 μF, 470 μF, 680 μF, 6.3 V/220 μF, 330 μF, 470 μF, 10 V/150 μF, 220 μF, 16 V/100 μF products in D case.
 Capacitance change of ±15% applies to all products with the B3 case.

See pages 25 and 26 for taping specifications.

MARKINGS

The standard marking shows capacitance, DC rated voltage, and polarity.

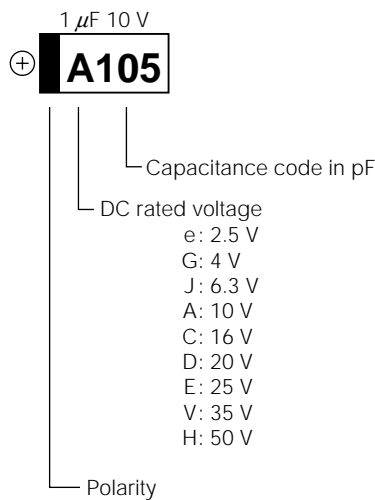

[A2, A cases]

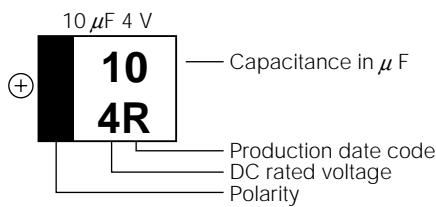

[B3, B2, and D2 cases]

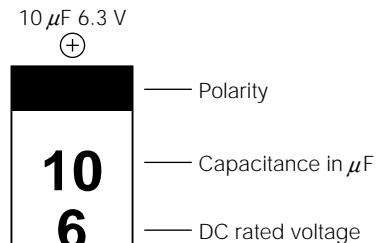

[B case]

[Marking of production date code]

y \ M	Jan.	Feb.	Mar.	Apr.	May	Jun.	Jul.	Aug.	Sep.	Oct.	Nov.	Dec.
2001	A	B	C	D	E	F	G	H	J	K	L	M
2002	N	P	Q	R	S	T	U	V	W	X	Y	Z
2003	a	b	c	d	e	f	g	h	j	k	l	m
2004	n	p	q	r	s	t	u	v	w	x	y	z

Note: Production date code will repeat beginning in 2005.

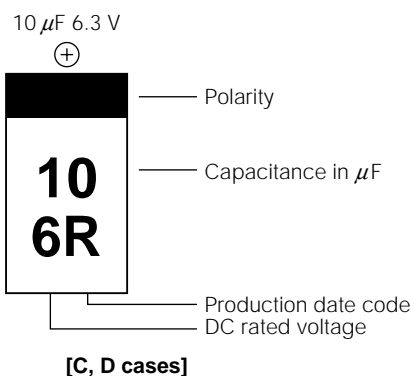

PART NUMBER SYSTEM

Bulk

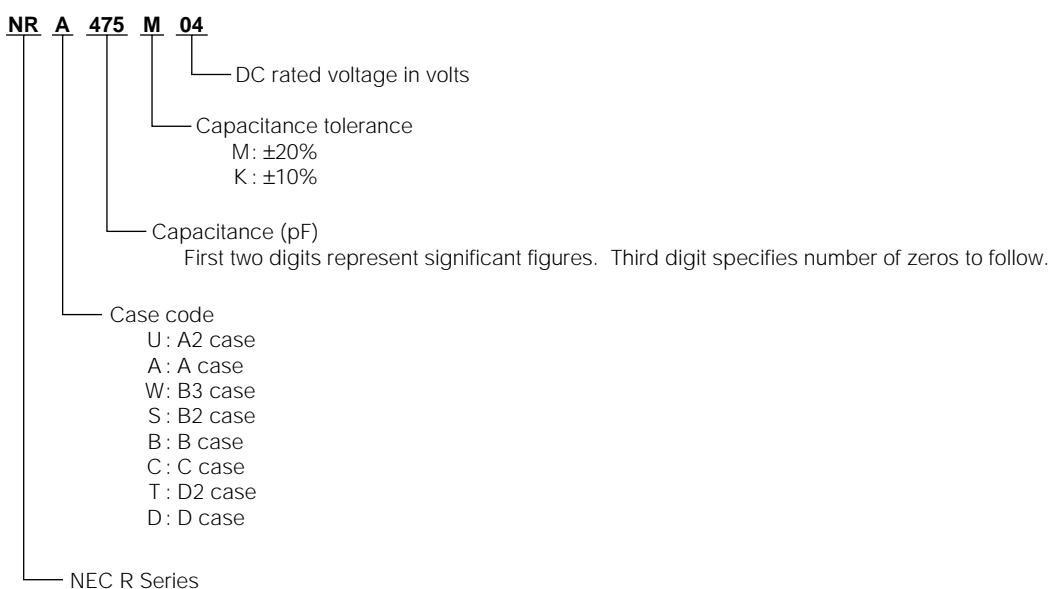

Tape and Reel

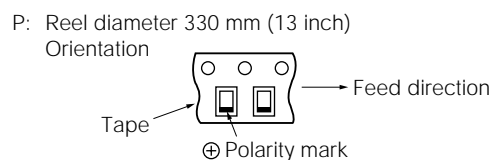
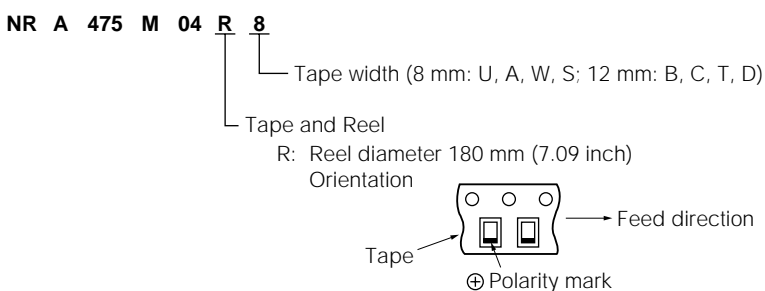

STANDARD RATINGS

Part Number	Capacitance (μF)	Case Code	DC Leakage Current (μA)	Tangent of Loss Angle
50 V Rating				
NRS474M50	0.47	B2	0.5	0.04
NRC684M50	0.68	C	0.5	0.04
NRC105M50	1	C	0.5	0.04
NRC155M50	1.5	C	0.7	0.04
NRD225M50	2.2	D	1.1	0.04
NRD335M50	3.3	D	1.6	0.04
NRT335M50	3.3	D2	1.6	0.04
NRD475M50	4.7	D	2.3	0.04
35 V Rating				
NRS474M35	0.47	B2	0.5	0.04
NRB474M35	0.47	B	0.5	0.04
NRS684M35	0.68	B2	0.5	0.04
NRB684M35	0.68	B	0.5	0.04
NRS105M35	1	B2	0.5	0.04
NRB105M35	1	B	0.5	0.04
NRC155M35	1.5	C	0.5	0.04
NRC225M35	2.2	C	0.7	0.04
NRC335M35	3.3	C	1.2	0.04
NRD335M35	3.3	D	1.2	0.04
NRT475M35	4.7	D2	1.6	0.04
NRD475M35	4.7	D	1.6	0.04
NRT685M35	6.8	D2	2.3	0.06
NRD685M35	6.8	D	2.3	0.06
25 V Rating				
NRA474M25	0.47	A	0.5	0.04
NRS155M25	1.5	B2	0.5	0.04
NRB155M25	1.5	B	0.5	0.04
NRC335M25	3.3	C	0.8	0.04
NRC475M25	4.7	C	1.1	0.04
NRT685M25	6.8	D2	1.7	0.06
NRD685M25	6.8	D	1.7	0.06
NRT106M25	10	D2	2.5	0.06
NRD106M25	10	D	2.5	0.06
20 V Rating				
NRA684M20	0.68	A	0.5	0.04
NRS225M20	2.2	B2	0.5	0.04
NRB225M20	2.2	B	0.5	0.04
NRC475M20	4.7	C	0.9	0.04
NRC685M20	6.8	C	1.4	0.06
NRT106M20	10	D2	2.0	0.06
NRD106M20	10	D	2.0	0.06
NRT156M20	15	D2	3.0	0.06
NRD156M20	15	D	3.0	0.06

Notes:

Part numbers are for ±20% capacitance tolerance.

Part Number	Capacitance (μF)	Case Code	DC Leakage Current (μA)	Tangent of Loss Angle
16 V Rating				
NRA105M16	1	A	0.5	0.04
NRA155M16	1.5	A	0.5	0.04
NRS335M16	3.3	B2	0.5	0.04
NRB335M16	3.3	B	0.5	0.04
NRC685M16	6.8	C	1.0	0.06
NRC106M16	10	C	1.6	0.06
NRT156M16	15	D2	2.4	0.06
NRD156M16	15	D	2.4	0.06
NRT226M16	22	D2	3.5	0.06
NRD226M16	22	D	3.5	0.06
10 V Rating				
NRA155M10	1.5	A	0.5	0.04
NRA225M10	2.2	A	0.5	0.04
NRS475M10	4.7	B2	0.5	0.04
NRB475M10	4.7	B	0.5	0.04
NRC106M10	10	C	1.0	0.06
NRC156M10	15	C	1.5	0.06
NRT226M10	22	D2	2.2	0.06
NRD226M10	22	D	2.2	0.06
NRT336M10	33	D2	3.3	0.06
NRD336M10	33	D	3.3	0.06
6.3 V Rating				
NRA225M06	2.2	A	0.5	0.04
NRA335M06	3.3	A	0.5	0.04
NRS685M06	6.8	B2	0.5	0.06
NRB685M06	6.8	B	0.5	0.06
NRC156M06	15	C	0.9	0.06
NRC226M06	22	C	1.4	0.06
NRT336M06	33	D2	2.0	0.06
NRD336M06	33	D	2.0	0.06
NRT476M06	47	D2	3.0	0.06
NRD476M06	47	D	3.0	0.06
4 V Rating				
NRA335M04	3.3	A	0.5	0.04
NRA475M04	4.7	A	0.5	0.04
NRS106M04	10	B2	0.5	0.06
NRB106M04	10	B	0.5	0.06
NRC226M04	22	C	0.8	0.06
NRC336M04	33	C	1.3	0.06
NRT476M04	47	D2	1.9	0.06
NRD476M04	47	D	1.9	0.06
NRT686M04	68	D2	2.7	0.06
NRD686M04	68	D	2.7	0.06

EXTENDED CHIPS STANDARD RATINGS

Part Number	Capacitance (μF)	Case Code	DC Leakage Current (μA)	Tangent of Loss Angle
35 V Rating				
NRA474M35	0.47	A	0.5	0.06
NRA684M35	0.68	A	0.5	0.06
NRA105M35	1	A	0.5	0.06
NRA155M35	1.5	A	0.5	0.06
NRS155M35	1.5	B2	0.5	0.06
NRB155M35	1.5	B	0.5	0.06
NRS225M35	2.2	B2	0.7	0.06
NRB225M35	2.2	B	0.7	0.06
NRS335M35	3.3	B2	1.1	0.06
NRC475M35	4.7	C	1.6	0.06
NRC685M35	6.8	C	2.3	0.06
NRT106M35	10	D2	3.5	0.06
NRD106M35	10	D	3.5	0.06
NRD156M35	15	D	5.2	0.06
25 V Rating				
NRA684M25	0.68	A	0.5	0.06
NRA105M25	1	A	0.5	0.06
NRA155M25	1.5	A	0.5	0.06
NRA225M25	2.2	A	0.5	0.06
NRS225M25	2.2	B2	0.5	0.06
NRS335M25	3.3	B2	0.8	0.06
NRB335M25	3.3	B	0.8	0.06
NRS475M25	4.7	B2	1.1	0.06
NRC685M25	6.8	C	1.7	0.06
NRC106M25	10	C	2.5	0.06
NRT156M25	15	D2	3.7	0.06
NRD156M25	15	D	3.7	0.06
NRD226M25	22	D	5.5	0.06
20 V Rating				
NRU474M20	0.47	A2	0.5	0.06
NRU684M20	0.68	A2	0.5	0.06
NRU105M20	1	A2	0.5	0.06
NRA105M20	1	A	0.5	0.06
NRU155M20	1.5	A2	0.5	0.06
NRA155M20	1.5	A	0.5	0.06
NRA225M20	2.2	A	0.5	0.06
NRA335M20	3.3	A	0.6	0.06
NRS335M20	3.3	B2	0.6	0.06
NRA475M20	4.7	A	0.9	0.06
NRS475M20	4.7	B2	0.9	0.06
NRB475M20	4.7	B	0.9	0.06
NRS685M20	6.8	B2	1.4	0.06
NRS106M20	10	B2	2.0	0.06
NRC106M20	10	C	2.0	0.06
NRC156M20	15	C	3.0	0.06
NRC226M20	22	C	4.4	0.06
NRT226M20	22	D2	4.4	0.06
NRD226M20	22	D	4.4	0.06
NRT336M20	33	D2	6.6	0.06
NRD336M20	33	D	6.6	0.06
NRD476M20	47	D	9.4	0.06

Notes:Part numbers are for $\pm 20\%$ capacitance tolerance.

Part Number	Capacitance (μF)	Case Code	DC Leakage Current (μA)	Tangent of Loss Angle
16 V Rating				
NRU684M16	0.68	A2	0.5	0.06
NRU105M16	1	A2	0.5	0.06
NRU155M16	1.5	A2	0.5	0.06
NRU225M16	2.2	A2	0.5	0.06
NRA225M16	2.2	A	0.5	0.06
NRA335M16	3.3	A	0.5	0.06
NRA475M16	4.7	A	0.7	0.06
NRS475M16	4.7	B2	0.7	0.06
NRA685M16	6.8	A	1.0	0.06
NRW685M16	6.8	B3	1.0	0.06
NRS685M16	6.8	B2	1.0	0.06
NRB685M16	6.8	B	1.0	0.06
NRA106M16	10	A	1.6	0.08
NRW106M16	10	B3	1.6	0.08
NRS106M16	10	B2	1.6	0.06
NRS156M16	15	B2	2.4	0.06
NRC156M16	15	C	2.4	0.06
NRS226M16	22	B2	3.5	0.06
NRC226M16	22	C	3.5	0.06
NRC336M16	33	C	5.2	0.06
NRT336M16	33	D2	5.2	0.06
NRD336M16	33	D	5.2	0.06
NRC476M16	47	C	7.5	0.06
NRT476M16	47	D2	7.5	0.06
NRD476M16	47	D	7.5	0.06
NRD686M16	68	D	10.8	0.06
NRD107M16	100	D	16	0.10
10 V Rating				
NRU105M10	1	A2	0.5	0.08
NRU155M10	1.5	A2	0.5	0.08
NRU225M10	2.2	A2	0.5	0.08
NRU335M10	3.3	A2	0.5	0.08
NRA335M10	3.3	A	0.5	0.08
NRU475M10	4.7	A2	0.5	0.08
NRA475M10	4.7	A	0.5	0.08
NRA685M10	6.8	A	0.6	0.08
NRS685M10	6.8	B2	0.6	0.08
NRU106M10	10	A2	1.0	0.08
NRA106M10	10	A	1.0	0.08
NRW106M10	10	B3	1.0	0.08
NRS106M10	10	B2	1.0	0.08
NRB106M10	10	B	1.0	0.08
NRW156M10	15	B3	1.5	0.06
NRS156M10	15	B2	1.5	0.08
NRA226M10	22	A	2.2	0.12
NRW226M10	22	B3	2.2	0.12
NRS226M10	22	B2	2.2	0.08
NRC226M10	22	C	2.2	0.08
NRS336M10	33	B2	3.3	0.08
NRC336M10	33	C	3.3	0.08
NRS476M10	47	B2	4.7	0.08
NRC476M10	47	C	4.7	0.08
NRT476M10	47	D2	4.7	0.08
NRD476M10	47	D	4.7	0.08
NRC686M10	68	C	6.8	0.08
NRT686M10	68	D2	6.8	0.08
NRD686M10	68	D	6.8	0.08
NRT107M10	100	D2	10	0.10
NRD107M10	100	D	10	0.08
NRD157M10	150	D	15	0.10
NRD227M10	220	D	22	0.12

Part Number	Capacitance (μF)	Case Code	DC Leakage Current (μA)	Tangent of Loss Angle
6.3 V Rating				
NRU155M06	1.5	A2	0.5	0.08
NRU225M06	2.2	A2	0.5	0.08
NRU335M06	3.3	A2	0.5	0.08
NRU475M06	4.7	A2	0.5	0.08
NRA475M06	4.7	A	0.5	0.08
NRU155M06	1.5	A2	0.5	0.08
NRU225M06	2.2	A2	0.5	0.08
NRU335M06	3.3	A2	0.5	0.08
NRU475M06	4.7	A2	0.5	0.08
NRA475M06	4.7	A	0.5	0.08
NRU685M06	6.8	A2	0.5	0.08
NRA685M06	6.8	A	0.5	0.08
NRU106M06	10	A2	0.6	0.08
NRA106M06	10	A	0.6	0.08
NRS106M06	10	B2	0.6	0.08
NRU156M06	15	A2	0.9	0.12
NRA156M06	15	A	0.9	0.08
NRW156M06	15	B3	0.9	0.08
NRS156M06	15	B2	0.9	0.08
NRB156M06	15	B	0.9	0.08
NRA226M06	22	A	1.4	0.10
NRW226M06	22	B3	1.3	0.12
NRS226M06	22	B2	1.3	0.08
NRA336M06	33	A	2.0	0.12
NRW336M06	33	B3	2.0	0.20
NRS336M06	33	B2	2.0	0.08
NRC336M06	33	C	2.0	0.08
NRA476M06	47	A	3.0	0.12
NRW476M06	47	B3	2.9	0.12
NRS476M06	47	B2	3.0	0.08
NRC476M06	47	C	3.0	0.08
NRS686M06	68	B2	4.2	0.10
NRC686M06	68	C	4.2	0.08
NRT686M06	68	D2	4.2	0.08
NRD686M06	68	D	4.2	0.08
NRS107M06	100	B2	6.3	0.12
NRC107M06	100	C	6.3	0.08
NRT107M06	100	D2	6.3	0.08
NRD107M06	100	D	6.3	0.08
NRC157M06	150	C	9.4	0.10
NRT157M06	150	D2	9.4	0.10
NRD157M06	150	D	9.4	0.08
NRC227M06	220	C	13.8	0.14
NRD227M06	220	D	13.8	0.12
NRD337M06	330	D	20.7	0.14
NRD477M06	470	D	29.7	0.20
4 V Rating				
NRU225M04	2.2	A2	0.5	0.08
NRU335M04	3.3	A2	0.5	0.08
NRU475M04	4.7	A2	0.5	0.08
NRU685M04	6.8	A2	0.5	0.08
NRA685M04	6.8	A	0.5	0.08
NRU106M04	10	A2	0.5	0.12
NRA106M04	10	A	0.5	0.08
NRU156M04	15	A2	0.6	0.12
NRA156M04	15	A	0.6	0.08
NRS156M04	15	B2	0.6	0.08
NRU226M04	22	A2	0.8	0.12
NRA226M04	22	A	0.8	0.06
NRW226M04	22	B3	0.8	0.08
NRS226M04	22	B2	0.8	0.08
NRB226M04	22	B	0.8	0.08
NRA336M04	33	A	1.3	0.10
NRW336M04	33	B3	1.3	0.12
NRS336M04	33	B2	1.3	0.08
NRA476M04	47	A	1.8	0.12
NRW476M04	47	B3	1.8	0.12

Part Number	Capacitance (μF)	Case Code	DC Leakage Current (μA)	Tangent of Loss Angle
4 V Rating				
NRS476M04	47	B2	1.8	0.08
NRC476M04	47	C	1.8	0.08
NRW686M04	68	B3	2.7	0.15
NRS686M04	68	B2	2.7	0.08
NRC686M04	68	C	2.7	0.08
NRW107M04	100	B3	4.0	0.20
NRS107M04	100	B2	4.0	0.12
NRC107M04	100	C	4.0	0.08
NRT107M04	100	D2	4.0	0.08
NRD107M04	100	D	4.0	0.08
NRS157M04	150	B2	6.0	0.18
NRC157M04	150	C	6.0	0.10
NRT157M04	150	D2	6.0	0.08
NRD157M04	150	D	6.0	0.08
NRC227M04	220	C	8.8	0.12
NRT227M04	220	D2	8.8	0.12
NRD227M04	220	D	8.8	0.08
NRC337M04	330	C	13.2	0.14
NRD337M04	330	D	13.2	0.14
NRD477M04	470	D	18.8	0.16
NRD687M04	680	D	27.2	0.24
2.5 V Rating				
NRU475M02	4.7	A2	0.5	0.08
NRU685M02	6.8	A2	0.5	0.08
NRU106M02	10	A2	0.5	0.08
NRU156M02	15	A2	0.5	0.12
NRA156M02	15	A	0.5	0.08
NRU226M02	22	A2	0.5	0.12
NRA226M02	22	A	0.5	0.08
NRA336M02	33	A	0.8	0.08
NRW336M02	33	B3	0.8	0.08
NRS336M02	33	B2	0.8	0.08
NRA476M02	47	A	1.1	0.12
NRW476M02	47	B3	1.1	0.12
NRS476M02	47	B2	1.1	0.08
NRA686M02	68	A	1.7	0.18
NRW686M02	68	B3	1.7	0.20
NRS686M02	68	B2	1.7	0.08
NRW107M02	100	B3	2.5	0.18
NRS107M02	100	B2	2.5	0.08
NRS157M02	150	B2	3.7	0.16
NRS227M02	220	B2	5.5	0.18
NRC227M02	220	C	5.5	0.12
NRT337M02	330	D2	8.2	0.14
NRC477M02	470	C	11.7	0.18
NRD477M02	470	D	11.7	0.14

SV/S Series Tantalum Chip Capacitors (Ultra-miniaturized)

DIMENSIONS [mm]

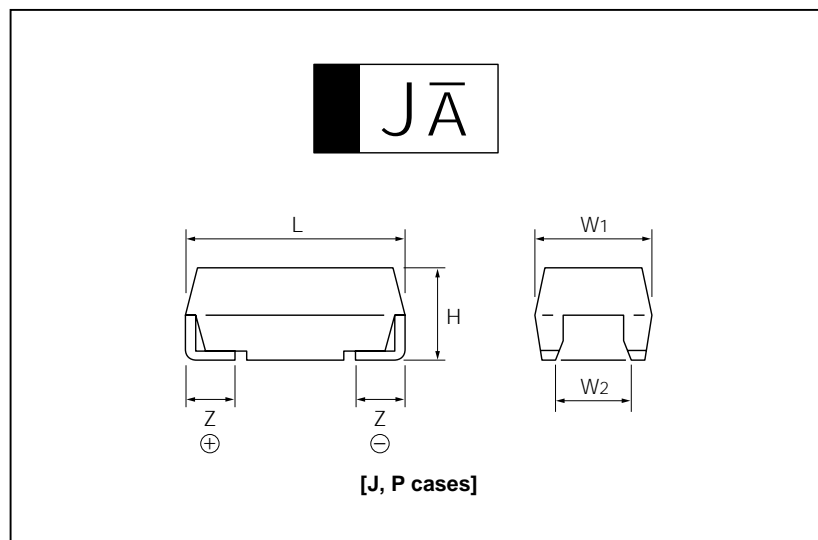

Case Code	EIA code	L	W ₁	W ₂	H	Z
J	1608	1.6 ± 0.1	0.8 ± 0.1	0.6 ± 0.1	0.8 ± 0.1	0.3 ± 0.15
P	2012	2.0 ± 0.2	1.25 ± 0.2	0.9 ± 0.2	1.1 ± 0.1	0.5 ± 0.1

C-V VALUE REFERENCE BY CASE CODE

DC Rated Voltage (Vdc) μF	2.5	4	6.3	10	16
0.47					P
0.68				P	P
1			P	P	J, P
1.5		P	P	J, P	
2.2	P	P	J, P	J, P	
3.3	P	P	J, P	P	
4.7	P	J, P	J, P	P	
6.8	P	J, P	P		
10	J, P	J, P	P		
15	P	P			
22	P	P			
33	P				

Markings [J case]

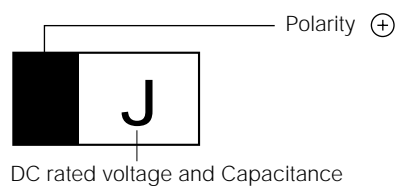

[J case Marking Code]

μF \ U _R	2.5 V	4 V	6.3 V	10 V	16 V
1					⊙
1.5				∇	
2.2			∩	<	
3.3			∩		
4.7		⊙	J		
6.8		G			
10	e				

PERFORMANCE CHARACTERISTICS

Operating temperature range
-55 to +125°C with proper voltage
derating as shown in the following table.

DC working voltage and surge voltage

Rated voltage	2.5	4	6.3	10	16	V	
Working	at 85°C	2.5	4	6.3	10	16	V
	at 125°C	1.6	2.5	4	6.3	10	V
Surge	at 85°C	3.3	5.2	8	13	20	V

Capacitance (at 20°C, 120 Hz)

Range: 0.47 μF to 33 μF

Tolerance: ±20%

Capacitance change with temperature

Not to exceed -20% at -55°C,

+20% at 85°C, and +20% at 125°C

Tangent of loss angle (at 20°C, 120 Hz)

Refer to Standard Ratings

DC leakage current (at 20°C)

0.01 C·V^{Note} μA or 0.5 μA, whichever is greater

Damp heat (90 to 95% RH at 40°C, 56 days (1344 h))

Capacitance change: ±20%

Tangent of loss angle: 150% of initial requirements

DC leakage current: initial requirements

Endurance (at 85°C, DC rated voltage, 2000 h)

Capacitance change: ±20%

Tangent of loss angle: initial requirements

DC leakage current: 200% of initial requirements

Resistance to soldering heat

Full immersion in solder, 260°C for 5 s.

Capacitance change: ±20%

Leakage current: initial requirements

Tangent of loss angle: initial requirements

See pages 25 and 26 for taping specifications.

Note: Product of capacitance in μF and voltage in V.

Markings

[P case]

up to 6.8 μF

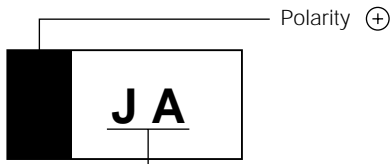

Polarity ⊕

Marking code
(corresponding to rated
voltage and capacitance)

over 10 μF

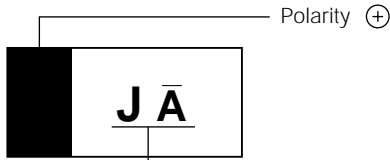

Polarity ⊕

Marking code
(corresponding to rated
voltage and capacitance)

[P case Marking Code]

DC Rated Voltage (Vdc)	2.5	4	6.3	10	16
0.47					CS
0.68				AW	CW
1			JA	AA	CA
1.5		GE	JE	AE	
2.2	eJ	GJ	JJ	AJ	
3.3	eN	GN	JN	AN	
4.7	eS	GS	JS	AS	
6.8	eW	GW	JW		
10	eĀ	GĀ	JĀ		
15	eĒ	GĒ			
22	eĴ	GĴ			
33	eN				

PART NUMBER SYSTEM

Bulk

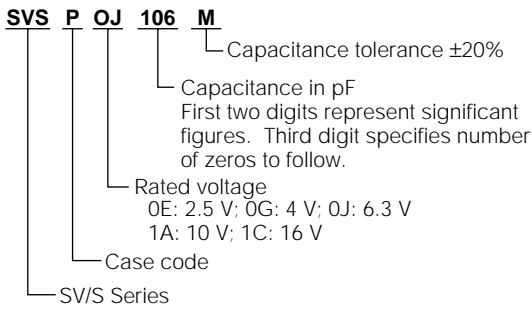

Tape and Reel

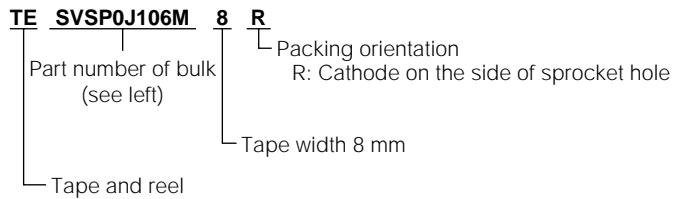

STANDARD RATINGS

Part Number	Capacitance (μF)	Case Code	DC Leakage Current (μA)	Tangent of Loss Angle
16 V Rating				
SVSP1C474M	0.47	P	0.5	0.1
SVSP1C684M	0.68	P	0.5	0.1
SVSJ1C105M	1.0	J	0.5	0.1
SVSP1C105M	1.0	P	0.5	0.2
10 V Rating				
SVSP1A684M	0.68	P	0.5	0.1
SVSP1A105M	1	P	0.5	0.1
SVSJ1A155M	1.5	J	0.5	0.2
SVSP1A155M	1.5	P	0.5	0.2
SVSJ1A225M	2.2	J	0.5	0.2
SVSP1A225M	2.2	P	0.5	0.2
SVSP1A335M	3.3	P	0.5	0.2
SVSP1A475M	4.7	P	0.5	0.2
6.3 V Rating				
SVSP0J105M	1	P	0.5	0.1
SVSP0J155M	1.5	P	0.5	0.1
SVSJ0J225M	2.2	J	0.5	0.2
SVSP0J225M	2.2	P	0.5	0.2
SVSJ0J335M	3.3	J	0.5	0.2
SVSP0J335M	3.3	P	0.5	0.2
SVSJ0J475M	4.7	J	0.5	0.2
SVSP0J475M	4.7	P	0.5	0.2
SVSP0J685M	6.8	P	0.5	0.2
SVSP0J106M	10	P	0.6	0.2

Part Number	Capacitance (μF)	Case Code	DC Leakage Current (μA)	Tangent of Loss Angle
4 V Rating				
SVSP0G155M	1.5	P	0.5	0.1
SVSP0G225M	2.2	P	0.5	0.1
SVSP0G335M	3.3	P	0.5	0.2
SVSJ0G475M	4.7	J	0.5	0.2
SVSP0G475M	4.7	P	0.5	0.2
SVSJ0G685M	6.8	J	0.5	0.2
SVSP0G685M	6.8	P	0.5	0.2
SVSJ0G106M	10	J	0.5	0.2
SVSP0G106M	10	P	0.5	0.2
SVSP0G156M	15	P	0.5	0.2
SVSP0G226M	22	P	0.8	0.2
2.5 V Rating				
SVSP0E225M	2.2	P	0.5	0.1
SVSP0E335M	3.3	P	0.5	0.1
SVSP0E475M	4.7	P	0.5	0.2
SVSP0E685M	6.8	P	0.5	0.2
SVSJ0E106M	10	J	0.5	0.2
SVSP0E106M	10	P	0.5	0.2
SVSP0E156M	15	P	0.5	0.2
SVSP0E226M	22	P	0.5	0.2
SVSP0E336M	33	P	0.8	0.2

SV/H Series Tantalum Chip Capacitors (Higher Performance)

DIMENSIONS [mm]

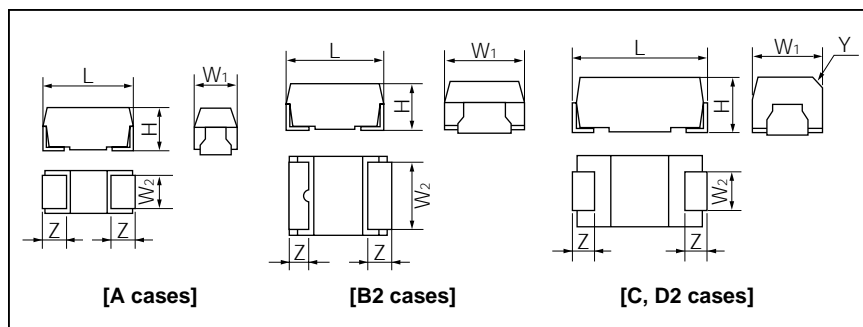

PERFORMANCE CHARACTERISTICS

Operating temperature range
-55 to +125°C with proper voltage
derating as shown in the following table.

DC working voltage and surge voltage

Rated voltage	10	16	20	25	35	V	
Working	at 85°C	10	16	20	25	35	V
	at 125°C	6.3	10	13	16	22	V
Surge	at 85°C	13	20	26	33	46	V

(Unit: mm)

Case Code	EIA code	L	W ₁	W ₂	H	Z	Y
A	3216	3.2 ± 0.2	1.6 ± 0.2	1.2 ± 0.1	1.6 ± 0.2	0.8 ± 0.2	-
B2	3528	3.5 ± 0.2	2.8 ± 0.2	2.3 ± 0.1	1.9 ± 0.2	0.8 ± 0.2	-
C	6032	6.0 ± 0.2	3.2 ± 0.2	2.2 ± 0.1	2.5 ± 0.2	1.3 ± 0.2	0.4 C
D2	5846	5.8 ± 0.2	4.6 ± 0.2	2.4 ± 0.1	3.2 ± 0.2	1.3 ± 0.2	-

Capacitance (at 20°C, 120 Hz)

Range: 0.47 μF to 33 μF

Tolerance: ±20%, ±10%

Capacitance change with temperature

Not to exceed -12% at -55°C, +12% at 85°C, and +15% at 125°C

Tangent of loss angle (at 20°C, 120 Hz)

0.47 μF to 4.7 μF: less than 0.04

6.8 μF to 33 μF: less than 0.06

DC leakage current (at 20°C)

0.01 C·V^{Note} μA or 0.5 μA, whichever is greater

Damp heat (85% RH at 85°C, 56 days (1344 h))

Capacitance change: ±10%

Tangent of loss angle: 150% of initial requirements

DC leakage current: initial requirements

Endurance (at 85°C, DC rated voltage, 2000 h)

Capacitance change: ±10%

Tangent of loss angle: initial requirements

DC leakage current: 125% of initial requirements

Resistance to soldering heat

(solder reflow and solder dip at 260°C, 10 s.)

Capacitance change: ±5%

Tangent of loss angle: initial requirements

DC leakage current: initial requirements

Rapid change of temperature (at -55 to 125°C, 1000 cycles)

Capacitance change: ±10%

Leakage current: initial requirements

Tangent of loss angle: initial requirements

Note: Product of capacitance in μF and voltage in V.

See pages 25 and 26 for taping specifications.

μF	DC rated voltage (Vdc)				
	10	16	20	25	35
0.47				A	B2
0.68			A		B2
1		A			B2
1.5		A		B2	C
2.2	A		B2		C
3.3		B2			C
4.7	B2			C	D2
6.8			C		D2
10		C		D2	
15	C		D2		
22		D2			
33	D2				

MARKINGS

The standard marking shows capacitance, DC rated voltage, polarity, and production date code.

–Top face–

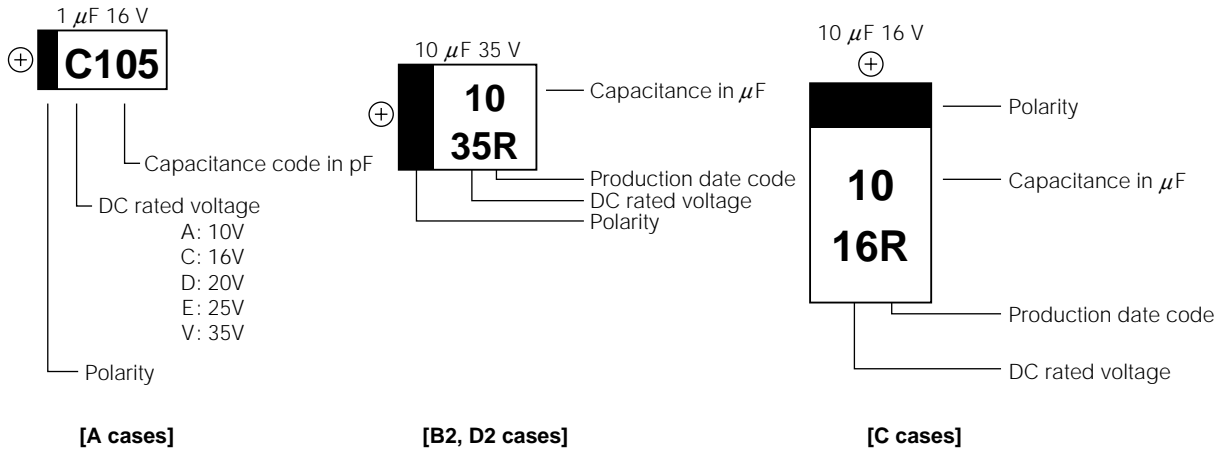

–Bottom face–
 [A case]

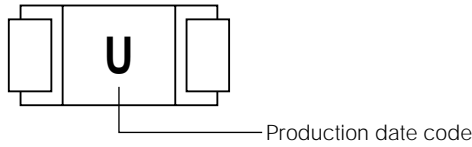

[Marking of production date code]

	Jan.	Feb.	Mar.	Apr.	May	Jun.	Jul.	Aug.	Sep.	Oct.	Nov.	Dec.
2001	A	B	C	D	E	F	G	H	J	K	L	M
2002	N	P	Q	R	S	T	U	V	W	X	Y	Z
2003	a	b	c	d	e	f	g	h	j	k	l	m
2004	n	p	q	r	s	t	u	v	w	x	y	z

Note: Production date code will repeat beginning in 2005.

PART NUMBER SYSTEM

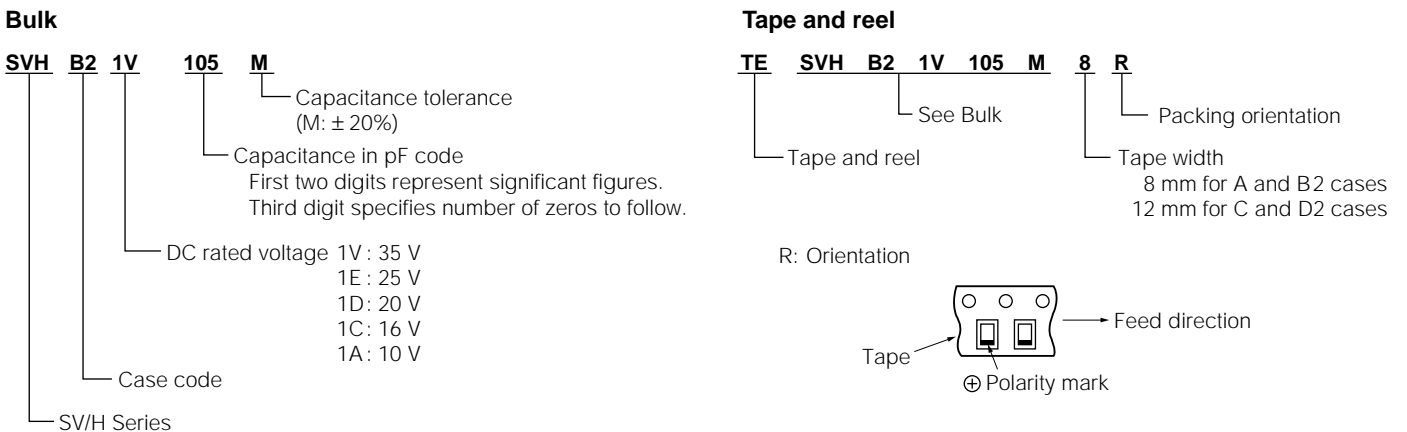

STANDARD RATINGS

Part Number	Capacitance (μF)	Case Code	DC Leakage Current (μA)	Tangent of Loss Angle
35 V Rating				
SVHB21V474M	0.47	B2	0.5	0.04
SVHB21V684M	0.68	B2	0.5	0.04
SVHB21V105M	1	B2	0.5	0.04
SVHC1V155M	1.5	C	0.5	0.04
SVHC1V225M	2.2	C	0.7	0.04
SVHC1V335M	3.3	C	1.2	0.04
SVHD21V475M	4.7	D2	1.6	0.04
SVHD21V685M	6.8	D2	2.3	0.06
25 V Rating				
SVHA1E474M	0.47	A	0.5	0.04
SVHB21E155M	1.5	B2	0.5	0.04
SVHC1E475M	4.7	C	1.1	0.04
SVHD21E106M	10	D2	2.5	0.06
20 V Rating				
SVHA1D684M	0.68	A	0.5	0.04
SVHB21D225M	2.2	B2	0.5	0.04
SVHC1D685M	6.8	C	1.4	0.06
SVHD21D156M	15	D2	3.0	0.06
16 V Rating				
SVHA1C105M	1	A	0.5	0.04
SVHA1C155M	1.5	A	0.5	0.04
SVHB21C335M	3.3	B2	0.5	0.04
SVHC1C106M	10	C	1.6	0.06
SVHD21C226M	22	D2	3.5	0.06
10 V Rating				
SVHA1A225M	2.2	A	0.5	0.04
SVHB21A475M	4.7	B2	0.5	0.04
SVHC1A156M	15	B	1.5	0.06
SVHD21A336M	33	D2	3.3	0.06

Note: Part numbers are for $\pm 20\%$ capacitance tolerance.

SV/F Series Tantalum Chip Capacitors (Fuse Built-in Type)

DIMENSIONS [mm]

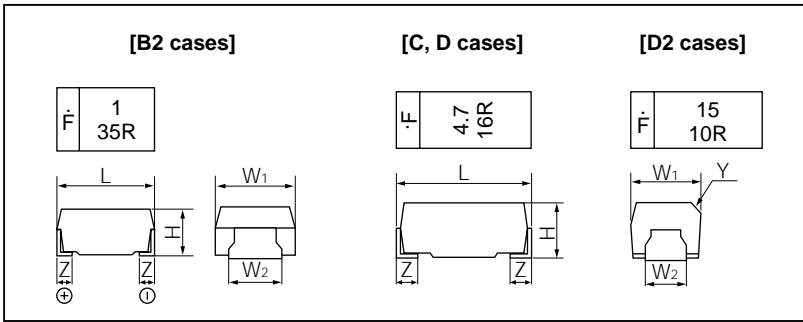

(Unit: mm)

Case Code	EIA code	L	W ₁	W ₂	H	Z	Y
B2	3528	3.5 ± 0.2	2.8 ± 0.2	2.3 ± 0.1	1.9 ± 0.2	0.8 ± 0.2	–
C	6032	6.0 ± 0.2	3.2 ± 0.2	2.2 ± 0.1	2.5 ± 0.2	1.3 ± 0.2	0.4 C
D2	5846	5.8 ± 0.2	4.6 ± 0.2	2.4 ± 0.1	3.2 ± 0.2	1.3 ± 0.2	–
D	7343	7.3 ± 0.2	4.3 ± 0.2	2.4 ± 0.1	2.8 ± 0.2	1.3 ± 0.2	0.5 C

DC Rated Voltage (Vdc) μF	10	16	20	25	35	50
1					B2	C
1.5				B2		
2.2			B2		C	
3.3		B2		C		D2
4.7	B2	C	C		D2, D	
6.8		C		D2, D	D	
10		C	D2, D	D		
15	C, D2	D2, D	D			
22		D2, D	D			
33	D2, D	D				
47	D					

PERFORMANCE CHARACTERISTICS

Operating temperature range
–55 to +125°C with proper voltage derating as shown in the following table.

DC working voltage and surge voltage

Rated voltage	10	16	20	25	35	50	V
Working	at 85°C	10	16	20	25	35	50
	at 125°C	6.3	10	13	16	22	32
Surge	at 85°C	13	20	26	33	46	65

Capacitance (at 20°C, 120 Hz)

Range: 1 μF to 47 μF
Tolerance: ± 20%, ± 10%

Capacitance change with temperature

Not to exceed –12% at –55°C, +12% at 85°C, and +15% at 125°C

Tangent of loss angle (at 20°C, 120 Hz)

1 μF to 4.7 μF: less than 0.04
6.8 μF to 47 μF: less than 0.06

DC leakage current (at 20°C)

0.01 C·V^{Note} μA or 0.5 μA, whichever is greater

Damp heat (90 to 95% RH at 40°C, 56 days (1344 h))

Capacitance change: ±5%
Tangent of loss angle: 150% of initial requirements
DC leakage current: initial requirements

Endurance (at 85°C, DC rated voltage, 2000 h)

Capacitance change: ±10%
Tangent of loss angle: initial requirements
DC leakage current: 125% of initial requirements

Resistance to soldering heat

(solder reflow at 260°C, 10 s.

or solder dip at 260°C, 5 s.)

Capacitance change: ±5%
Leakage current: initial requirements
Tangent of loss angle: initial requirements

Fuse blow-out characteristic

Blow-out time:

B2 case: 5 s Max. with 2 A applied

C case: 10 s Max. with 2 A applied

D2, D cases: 20 s Max. with 2 A applied

Note: Product of capacitance in μF and voltage in V.

See pages 25 and 26 for taping specifications.

MARKINGS

The standard marking shows capacitance, DC rated voltage, polarity, and fuse built-in type.

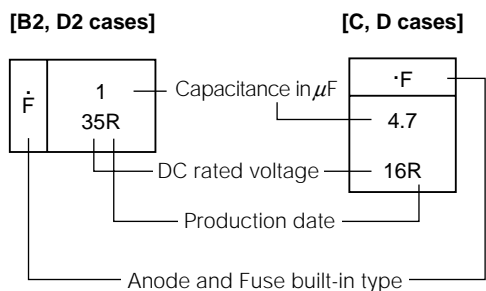

[Marking of production date code]

Y	M	Jan.	Feb.	Mar.	Apr.	May	Jun.	Jul.	Aug.	Sep.	Oct.	Nov.	Dec.
2001		A	B	C	D	E	F	G	H	J	K	L	M
2002		N	P	Q	R	S	T	U	V	W	X	Y	Z
2003		a	b	c	d	e	f	g	h	j	k	l	m
2004		n	p	q	r	s	t	u	v	w	x	y	z

Note: Production date code will repeat beginning in 2005.

PART NUMBER SYSTEM

Bulk

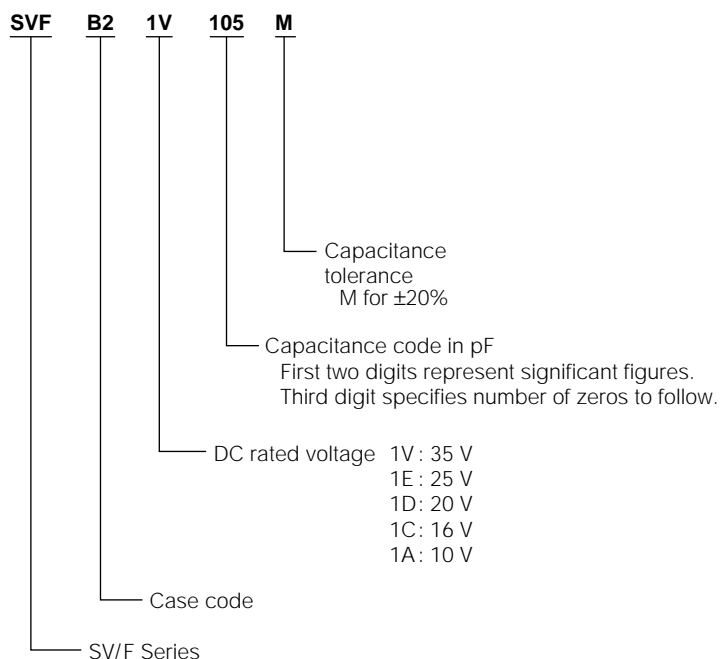

Tape and Reel

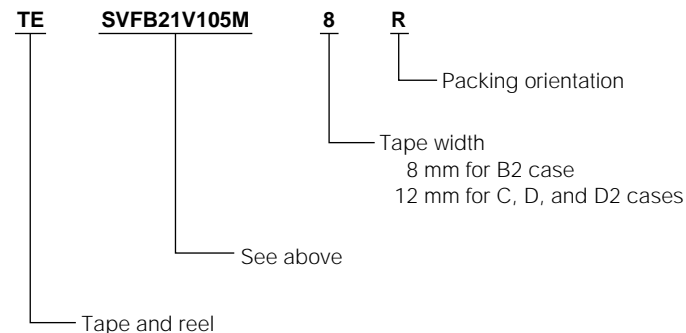

R: Orientation

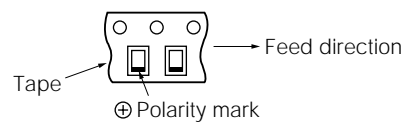

STANDARD RATINGS

Part Number	Capacitance (μF)	Case Code	DC Leakage Current (μA)	Tangent of Loss Angle
50 V Rating				
SVFC1H105M	1	C	0.5	0.04
SVFD21H335M	3.3	D2	1.7	0.04
35 V Rating				
SVFB21V105M	1	B2	0.5	0.04
SVFC1V225M	2.2	C	0.7	0.04
SVFD21V475M	4.7	D2	1.6	0.04
SVFD1V475M	4.7	D	1.6	0.04
SVFD1V685M	6.8	D	2.5	0.06
25 V Rating				
SVFB21E155M	1.5	B2	0.5	0.04
SVFC1E335M	3.3	C	0.8	0.04
SVFD21E685M	6.8	D2	1.7	0.06
SVFD1E685M	6.8	D	1.7	0.06
SVFD1E106M	10	D	2.5	0.06
20 V Rating				
SVFB21D225M	2.2	B2	0.5	0.04
SVFC1D475M	4.7	C	0.9	0.04
SVFD21D106M	10	D2	2.0	0.06
SVFD1D106M	10	D	2.0	0.06
SVFD1D156M	15	D	3.0	0.06
SVFD1D226M	22	D	4.4	0.06
16 V Rating				
SVFB21D335M	3.3	B2	0.5	0.04
SVFC1C475M	4.7	C	0.7	0.04
SVFC1C685M	6.8	C	1.0	0.06
SVFC1C106M	10	C	1.6	0.06
SVFD21C156M	15	D2	2.4	0.06
SVFD21C226M	22	D2	3.5	0.06
SVFD1C156M	15	D	2.4	0.06
SVFD1C226M	22	D	3.5	0.06
SVFD1C336M	33	D	5.3	0.06
10 V Rating				
SVFB21A475M	4.7	B2	0.5	0.04
SVFC1A156M	15	C	1.5	0.06
SVFD21A156M	15	D2	1.5	0.06
SVFD21A336M	33	D2	3.3	0.06
SVFD1A336M	33	D	3.3	0.06
SVFD1A476M	47	D	4.7	0.06

Note: Part numbers are for ±20% capacitance tolerance.

SV/Z Series Tantalum Chip Capacitors (Low-ESR Type)

DIMENSIONS [mm]

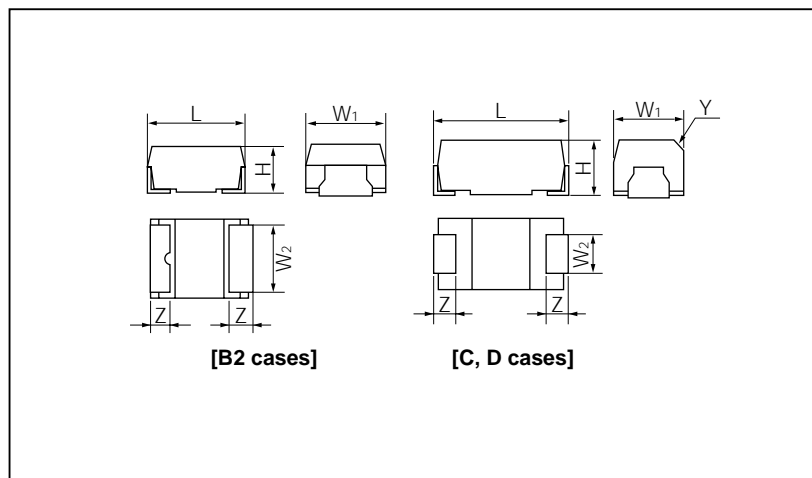

Case Code	EIA code	L	W ₁	W ₂	H	Z	Y
B2	3528	3.5 ± 0.2	2.8 ± 0.2	2.3 ± 0.1	1.9 ± 0.2	0.8 ± 0.2	–
C	6032	6.0 ± 0.2	3.2 ± 0.2	2.2 ± 0.1	2.5 ± 0.2	1.3 ± 0.2	0.4 C
D	7343	7.3 ± 0.2	4.3 ± 0.2	2.4 ± 0.1	2.8 ± 0.2	1.3 ± 0.2	0.5 C

DC Rated Voltage (Vdc)	DC Rated Voltage (Vdc)		
	4	6.3	10
10			B2
15			
22		B2	C
33			C
47			C
68			
100			D
150		D	D
220	D	D	
330	D		

PERFORMANCE CHARACTERISTICS

Operating temperature range
–55 to +125°C with proper voltage derating as shown in the following table.

DC working voltage and surge voltage

Rated voltage	4	6.3	10	V	
Working	at 85°C	4	6.3	10	V
	at 125°C	2.5	5	8	V
Surge	at 85°C	5.2	8	13	V

Capacitance (at 20°C, 120 Hz)
Range: 10 μF to 330 μF
Tolerance: ± 20%

Capacitance change with temperature
Not to exceed –12% at –55°C, +12% at 85°C, and +15% at 125°C

Tangent of loss angle (at 20°C, 120 Hz)
Refer to Standard Ratings

DC leakage current (at 20°C)
0.01 C·V⁽¹⁾ μA or 0.5 μA, whichever is greater

Equivalent series resistance (ESR)(at 20°C, 100 kHz)
Refer to Standard Ratings

Damp heat (90 to 95% RH at 40°C, 56 days (1344 h))
Capacitance change: ± 5% (±12%)⁽²⁾
Tangent of loss angle: 150% of initial requirements
DC leakage current: initial requirements

Endurance (at 85°C, DC rated voltage, 2000 h)
Capacitance change: ±10% (±12%)⁽²⁾
Tangent of loss angle: initial requirements
DC leakage current: 125% of initial requirements

Resistance to soldering heat
(solder reflow at 260°C, 10 s. or solder dip at 260°C, 5 s.)
Capacitance change: ±5% (±12%)⁽²⁾
Tangent of loss angle: initial requirements
DC leakage current: initial requirements

Note 1 Product of capacitance in μF and voltage in V.

2 Capacitance change of ±12% applies to 10 V/150 μF, 6.3 V/220 μF, 4 V/330 μF products in D case.

See pages 25 and 26 for taping specifications.

MARKINGS

The standard marking shows capacitance, DC rated voltage, polarity, and production date code.

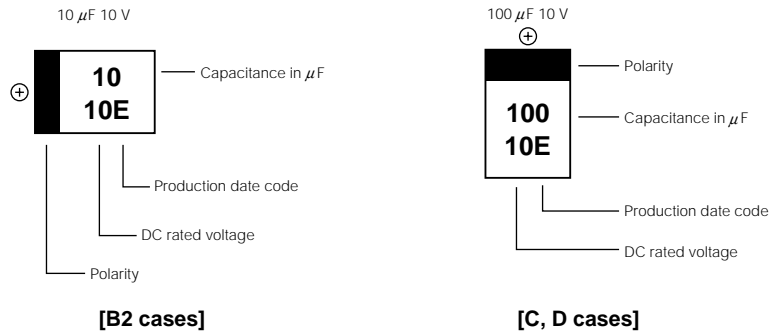

[Marking of production date code]

	Jan.	Feb.	Mar.	Apr.	May	Jun.	Jul.	Aug.	Sep.	Oct.	Nov.	Dec.
2001	A	B	C	D	E	F	G	H	J	K	L	M
2002	N	P	Q	R	S	T	U	V	W	X	Y	Z
2003	a	b	c	d	e	f	g	h	j	k	l	m
2004	n	p	q	r	s	t	u	v	w	x	y	z

Note: Production date code will repeat beginning in 2005.

PART NUMBER SYSTEM

Bulk

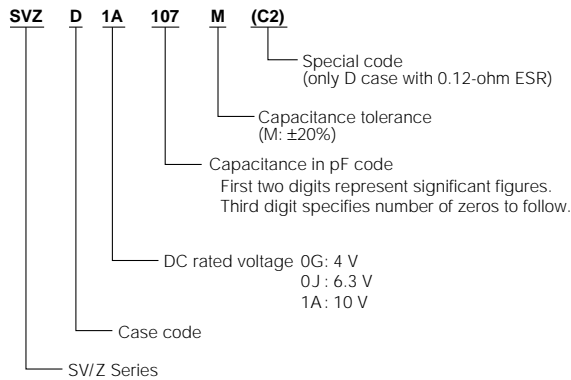

Tape and Reel

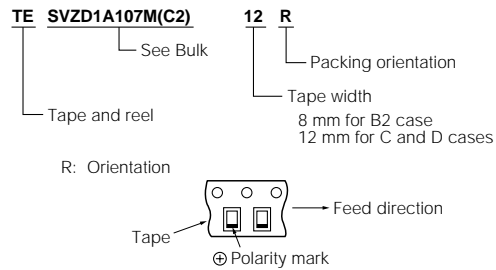

STANDARD RATINGS

Part Number	Capacitance (μ F)	Case Code	DC Leakage Current (μ A)	Tangent of Loss Angle	ESR (Ω)
10 V Rating					
SVZB21A106M	10	B2	1.0	0.08	0.9
SVZC1A226M	22	C	2.2	0.08	0.5
SVZC1A336M	33	C	3.3	0.08	0.4
SVZC1A476M	47	C	4.7	0.08	0.3
SVZD1A107M	100	D	10.0	0.08	0.1
SVZD1A157M	150	D	15.0	0.10	0.1
6.3 V Rating					
SVZB20J226M	22	B2	1.3	0.08	0.8
SVZD0J157M	150	D	9.4	0.08	0.1
SVZD0J157M(C2)	150	D	9.4	0.08	0.12
SVZD0J227M	220	D	13.8	0.12	0.1
4 V Rating					
SVZD0G227M	220	D	8.8	0.08	0.1
SVZD0G227M(C2)	220	D	8.8	0.08	0.12
SVZD0G337M	330	D	13.2	0.14	0.1

TAPE AND REEL SPECIFICATIONS

PLASTIC TAPE CARRIER

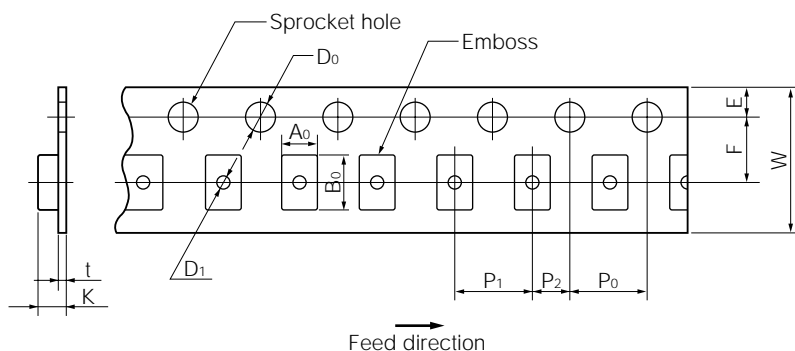

Unit: mm

Case Code	$A_0 \pm 0.2$	$B_0 \pm 0.2$	$K \pm 0.2$
J	1.0	1.8	1.1
P	1.4	2.2	1.4
A2	1.9	3.5	1.4
A	1.9	3.5	1.9
B3	3.2	3.8	1.4
B2	3.3	3.8	2.1
B	3.1	5.1	2.6
C	3.7	6.4	3.0
D2	5.1	6.2	3.6
D	4.8	7.7	3.3

Case Code	$W \pm 0.3$	$F \pm 0.05$	$E \pm 0.1$	$P_1 \pm 0.1$	$P_2 \pm 0.05$	$P_0 \pm 0.1$	$D_0^{+0.1}_0$	t	D1
J, P, A2, A, B3, B2	8	3.5	1.75	4	2	4	$\phi 1.5$	0.2	$\phi 1.0$
B	12	5.5		8				0.3	$\phi 1.5$
C			0.3						
D2			0.4						
D	0.3								

REEL

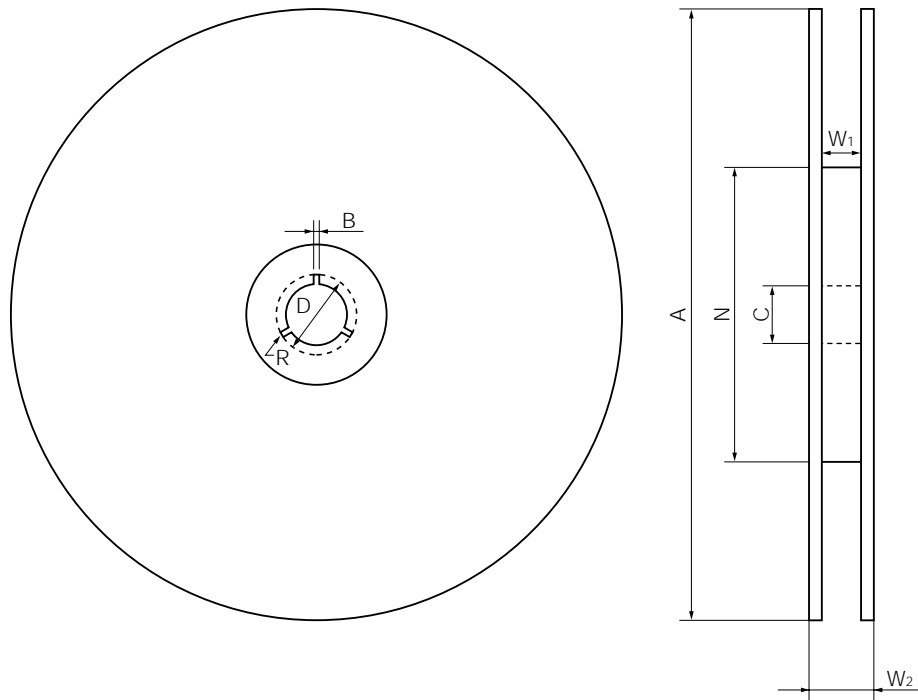

Unit: mm

Tape Width	A ± 2	N Min.	C ± 0.5	D ± 0.5	B ± 0.5	W ₁	W ₂ Max.	R
8 mm	φ180	φ50	φ13	φ21	2	9.0 ± 0.3	11.4 ± 1.0	1
12 mm						13.0 ± 0.3	15.4 ± 1.0	
8 mm	φ330	φ80	φ13	φ21	2	9.5 ± 0.5	14.5 Max.	1
12 mm						13.5 ± 0.5	18.5Max.	

Case Code	φ180 Reel	φ330 Reel
J	4000	—
P	3000	—
A2 (U)	3000	10,000
A	2000	9000
B3 (W)	3000	—
B2 (S)	2000	5000
B	1500	5000
C, D2 (Y), D	500	2500

[Quantity Per Reel]

CONDUCTIVE POLYMER TANTALUM CAPACITORS (NeoCapacitors)

PS/L Series NeoCapacitors

DIMENSIONS [mm]

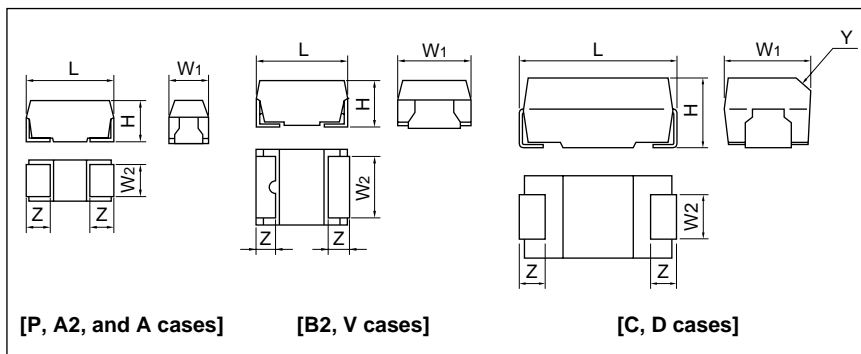

Unit: mm

Case Code	EIA code	L	W ₁	W ₂	H	Z	Y
J	–	1.6 ± 0.1	0.8 ± 0.1	0.6 ± 0.1	0.8 ± 0.1	0.3 ± 0.15	–
P	2012	2.0 ± 0.2	1.25 ± 0.2	0.9 ± 0.1	1.1 ± 0.1	0.5 ± 0.1	–
A2 (U)	3216L	3.2 ± 0.2	1.6 ± 0.2	1.2 ± 0.1	1.1 ± 0.1	0.8 ± 0.2	–
A	3216H	3.2 ± 0.2	1.6 ± 0.2	1.2 ± 0.1	1.6 ± 0.2	0.8 ± 0.2	–
B3 (W)	–	3.5 ± 0.2	2.8 ± 0.2	2.2 ± 0.1	1.1 ± 0.1	0.8 ± 0.2	–
B2 (S)	3528	3.5 ± 0.2	2.8 ± 0.2	2.3 ± 0.1	1.9 ± 0.2	0.8 ± 0.2	–
C	6032	6.0 ± 0.2	3.2 ± 0.2	2.2 ± 0.1	2.5 ± 0.2	1.3 ± 0.2	0.4 C
V	–	7.3 ± 0.2	4.3 ± 0.2	2.4 ± 0.1	1.9 ± 0.1	1.3 ± 0.2	–
D	7343	7.3 ± 0.2	4.3 ± 0.2	2.4 ± 0.1	2.8 ± 0.2	1.3 ± 0.2	0.5 C

DC Rated Voltage (Vdc)	4	6.3	10
2.2		J	
3.3		J, P	A
4.7		J, P	A2, A
6.8		P, A	A, B2
10	P, A	P, A2, A	A, B2
15		A, B2	B2, C
22	B2	A, B3, B2	B2, C
33	A	B3, B2	B2, C
47	A, B3	B2, C	C, V, D
68	C	C	V, D
100	B2	B2, C	V, D
150	C	C, V, D	D
220	V, D	D	
330	D	D	
470	D		

PERFORMANCE CHARACTERISTICS

Operating temperature range
–55 to +105°C with no voltage derating

Surge voltage

Rated voltage	4	6.3	10	V
Surge	5.2	8	13	V

Capacitance (at 20°C, 1 kHz)
Range: 2.2 μF to 470 μF
Tolerance: ±20%

Capacitance change with temperature
Not to exceed –20% at –55°C, +50% at 85°C

Tangent of loss angle (at 20°C, 1 kHz)
Refer to Standard Ratings

DC leakage current (at 20°C)
0.1 C•V^{Note} μA or 3 μA, whichever is greater

Equivalent series resistance (ESR)
(at 20°C, 100 kHz)
Refer to Standard Ratings

Damp heat (90 to 95% RH at 40°C, 500 h)
Capacitance: +30% to –20% of rated capacitance
Tangent of loss angle: 150% of initial requirements
DC leakage current: initial requirements

Endurance (at 85°C, DC rated voltage, 1000 h)
Capacitance change: ±20%
Tangent of loss angle: 150% of initial requirements
DC leakage current: initial requirements

Resistance to soldering heat
(solder reflow at 240°C, 10 s.)
Capacitance change: ±20%
Tangent of loss angle: initial requirements
DC leakage current: initial requirements

Permissible ripple current
0.5 Ap-p (J case)
0.7 Ap-p (P case)
1 Ap-p (A2, A cases)
1.5 Ap-p (B3, B2 cases)
2.0 Ap-p (C case)
2.5 Ap-p (V case)
2.5 Ap-p (D case)

Note: Product of capacitance in μF and voltage in V.

See pages 31 and 32 for taping specifications.

MARKINGS

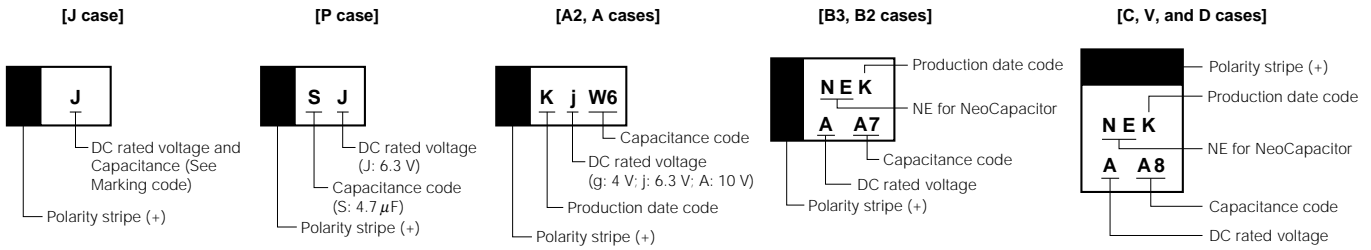

[J case Marking code]

μ F \ U _R	4 V	6.3 V	10 V
2.2		Г	
3.3		↵	
4.7		J	
6.8			
10			

[P case Marking code]

μ F \ U _R	4 V	6.3 V	10 V
3.3		NJ	
4.7		SJ	
6.8		WJ	
10	AG	AJ	

[Capacitance code]

Code	A	E	J	N	S	W	Code	6	7	8
Number	1	1.5	2.2	3.3	4.7	6.8	Multiplier	10^6	10^7	10^8

Example: A7 = $1.0 \times 10^7 = 10^7$ (pF) = 10 μ F

[Production date code]

Month \ Year	Jan.	Feb.	Mar.	Apr.	May	Jun.	Jul.	Aug.	Sep.	Oct.	Nov.	Dec.
2001	A	B	C	D	E	F	G	H	J	K	L	M
2002	N	P	Q	R	S	T	U	V	W	X	Y	Z
2003	a	b	c	d	e	f	g	h	j	k	l	m
2004	n	p	q	r	s	t	u	v	w	x	y	z

Note: Date code will repeat beginning in 2005.

PART NUMBER SYSTEM

Bulk

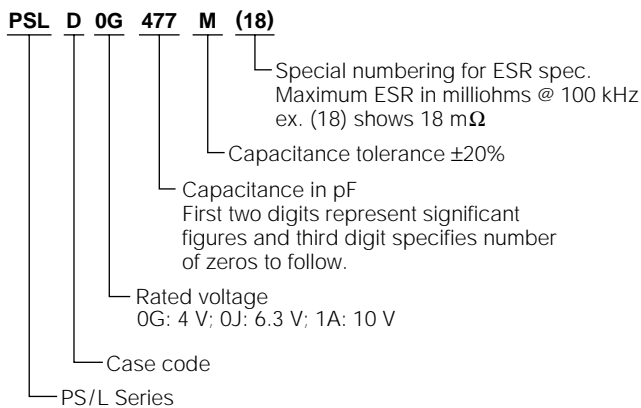

Tape and Reel

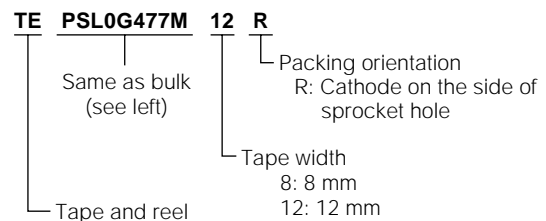

STANDARD RATINGS

Part Number	Capacitance (μF)	Case Code	DC Leakage Current (μA)	Tangent of Loss Angle	ESR ($\text{m}\Omega$)	Permissible Ripple Current (Ap-p)
4 V Rating						
PSLP0G106M	10	P	4	0.06	500	0.7
PSLA0G106M	10	A	4	0.06	500	1.0
PSLB20G226M	22	B2	8.8	0.08	300	1.5
PSLA0G336M	33	A	13.2	0.06	500	0.7
PSLA0G476M	47	A	18.8	0.06	200	1.0
PSLB30G476M	47	B3	18.8	0.10	80	1.5
PSLC0G686M	68	C	27.2	0.09	100	2.0
PSLB20G107M	100	B2	40	0.08	70	1.5
PSLC0G157M	150	C	60	0.09	100	2.0
PSLV0G227M	220	V	88	0.10	45	2.5
PSLV0G227M(25)	220	V	88	0.10	25	2.5
PSLD0G227M	220	D	88	0.10	55	2.5
PSLD0G227M(40)	220	D	88	0.10	40	2.5
PSLD0G227M(25)	220	D	88	0.10	25	2.5
PSLD0G337M	330	D	132	0.10	40	2.5
PSLD0G337M(25)	330	D	132	0.10	25	2.5
PSLD0G477M	470	D	188	0.10	25	2.5
PSLD0G477M(18)	470	D	188	0.10	18	2.5
6.3 V Rating						
PSLJ0J225M	2.2	J	10	0.04	600	0.5
PSLJ0J335M	3.3	J	10	0.04	600	0.5
PSLP0J335M	3.3	P	3	0.06	500	0.7
PSLJ0J475M	4.7	J	10	0.04	600	0.5
PSLP0J475M	4.7	P	2.9	0.06	500	0.7
PSLP0J685M	6.8	P	4.28	0.06	500	0.7
PSLA0J685M	6.8	A	4.2	0.06	800	1.0
PSLP0J106M	10	P	6.3	0.06	500	0.7
PSLA20J106M	10	A2	6.3	0.06	500	1.0
PSLA0J106M	10	A	6.3	0.06	500	1.0
PSLA0J156M	15	A	9.45	0.06	500	1.0
PSLB20J156M	15	B2	9.4	0.08	300	1.5
PSLA0J226M	22	A	13.8	0.06	500	1.0
PSLB30J226M	22	B3	13.9	0.10	80	1.5
PSLB20J226M	22	B2	13.8	0.08	300	1.5
PSLB30J336M	33	B3	20.8	0.10	80	1.5
PSLB20J336M	33	B2	20.7	0.08	300	1.5
PSLB20J476M	47	B2	29.6	0.08	200	1.5
PSLB20J476M(70)	47	B2	29.6	0.08	70	1.5
PSLC0J476M	47	C	29.6	0.09	100	2.0
PSLC0J686M	68	C	42.8	0.09	100	2.0
PSLB20J107M	100	B2	6.3	0.08	70	1.5
PSLB20J107M(45)	100	B2	6.3	0.08	45	1.5
PSLC0J107M	100	C	63.0	0.09	100	2.0
PSLC0J157M	150	C	94.5	0.09	100	2.0
PSLC0J157M(55)	150	C	94.5	0.09	55	2.0
PSLV0J157M	150	V	94.5	0.10	45	2.5
PSLD0J157M	150	D	94.5	0.10	55	2.5
PSLD0J157M(40)	150	D	94.5	0.10	40	2.5
PSLD0J157M(25)	150	D	94.5	0.10	25	2.5
PSLD0J227M	220	D	138.6	0.10	55	2.5
PSLD0J227M(40)	220	D	138.6	0.10	55	2.5
PSLD0J337M	330	D	207.9	0.10	40	2.5
PSLD0J337M(25)	330	D	207.9	0.10	25	2.5

Part Number	Capacitance (μF)	Case Code	DC Leakage Current (μA)	Tangent of Loss Angle	ESR (mΩ)	Permissible Ripple Current (Ap-p)
10 V Rating						
PSLA1A335M	3.3	A	3.3	0.06	800	1.0
PSLA21A475M	4.7	A2	4.7	0.06	500	1.0
PSLA1A475M	4.7	A	4.7	0.06	800	1.0
PSLA1A685M	6.8	A	6.8	0.06	800	1.0
PSLB21A685M	6.8	B2	6.8	0.08	500	1.5
PSLA1A106M	10	A	10	0.06	300	1.0
PSLB21A106M	10	B2	10	0.08	300	1.5
PSLB21A156M	15	B2	9.5	0.08	300	1.5
PSLC1A156M	15	C	15	0.08	200	2.0
PSLB21A226M	22	B2	13.8	0.08	300	1.5
PSLC1A226M	22	C	22	0.09	150	2.0
PSLB21A336M	33	B2	33	0.08	200	2.0
PSLC1A336M	33	C	33	0.08	100	2.0
PSLC1A476M	47	C	47	0.09	100	2.0
PSLV1A476M	47	V	47	0.10	60	2.5
PSLD1A476M	47	D	47	0.10	100	2.5
PSLV1A686M	68	V	68	0.10	60	2.5
PSLD1A686M	68	D	68	0.10	100	2.5
PSLV1A107M	100	V	100	0.10	45	2.5
PSLD1A107M	100	D	100	0.10	55	2.5
PSLD1A157M	150	D	150	0.10	55	2.5
PSLD1A157M(40)	150	D	150	0.10	40	2.5

TAPE AND REEL SPECIFICATIONS

Plastic Tape Carrier

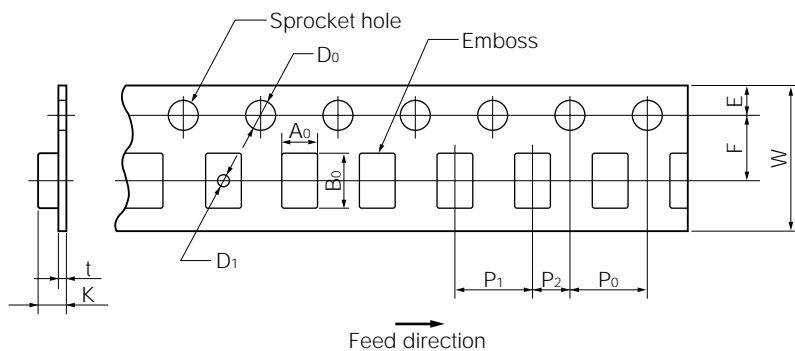

Unit: mm

Case Code	$A_0 \pm 0.2$	$B_0 \pm 0.2$	$K \pm 0.2$
J	1.0	1.8	1.1
P	1.4	2.2	1.4
A2 (U)	1.9	3.5	1.4
A	1.9	3.5	1.9
B3	3.2	3.8	1.4
B2 (S)	3.3	3.8	2.1
C	3.7	6.4	3.0
V	4.6	7.7	2.4
D	4.8	7.7	3.3

Case Code	$W \pm 0.3$	$F \pm 0.05$	$E \pm 0.1$	$P_1 \pm 0.1$	$P_2 \pm 0.05$	$P_0 \pm 0.1$	$D_0^{+0.1}$	$D_1^{+0.1}$	t
J	8	3.5	1.75	4	2	4	$\phi 1.5$	-	0.2
P								-	
A2 (U)									
A									
B3 (W)									
B2 (S)									
C	12	5.5		8				$\phi 1.5$	0.3
V									0.4
D									0.3

REEL

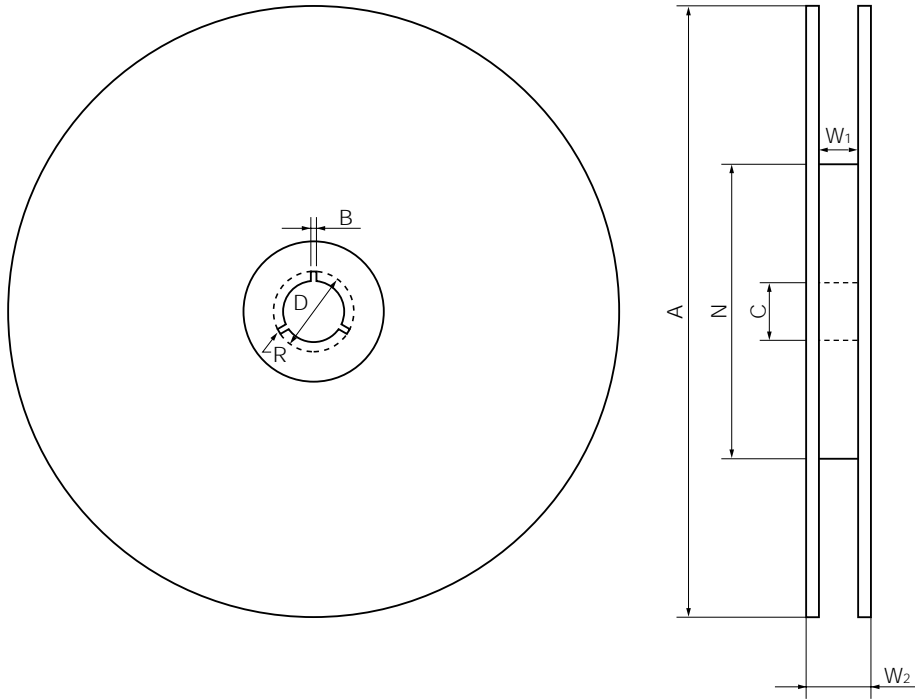

Unit: mm

Tape Width	A ± 2	N Min.	C ± 0.5	D ± 0.5	B ± 0.5	W ₁	W ₂ Max.	R
8 mm	φ180	φ50	φ13	φ21	2	9.0 ± 0.3	11.4 ± 1.0	1
12 mm						13.0 ± 0.3	15.4 ± 1.0	
8 mm	φ330	φ80	φ13	φ21	2	9.5 ± 0.5	14.5 Max.	1
12 mm						13.5 ± 0.5	18.5 Max.	

Case Code	φ180 Reel	φ330 Reel
J	4000	—
P	3000	—
A2 (U)	3000	10,000
A	2000	9000
B3 (W)	3000	—
B2 (S)	2000	5000
V	1000	3000
C, D	500	2500

[Quantity Per Reel]

NOTES ON USING THE SOLID TANTALUM CAPACITORS

1. Circuit Design

(1) Reliability

The reliability of the solid tantalum capacitor is heavily influenced by environmental conditions such as temperature, humidity, shock, vibration, mechanical stresses, and electric stresses, including applied voltage, current, ripple current, transient current and voltage, and frequency. When using solid tantalum capacitors, therefore, provide enough margin so that the reliability of the capacitors is maintained.

Voltage and temperature are important parameters when estimating the reliability (field failure rate).

The field failure rate of a solid tantalum capacitor can be calculated by the following expression if emphasis is placed only on the voltage and temperature:

$$\lambda = \lambda_0(V/V_0)^3 \times 2^{(T-T_0)/10}$$

Where

λ : estimated failure rate in actual working condition
temperature: T; voltage: V

λ_0 : failure rate under rated load (See table below.)
temperature: T_0 ; voltage: V_0

Failure rate level λ_0 of each series

Series	Failure rate level
PS/L	1%/1000 h
R (standard)	1%/1000 h
R (extended)	1%/1000 h
SV/S	1%/1000 h
SV/H	0.5%/1000 h
SV/F	1%/1000 h
SV/Z	1%/1000 h

<Test conditions>

Temperature: 85°C
Voltage: rated voltage
Rs: 3 Ω

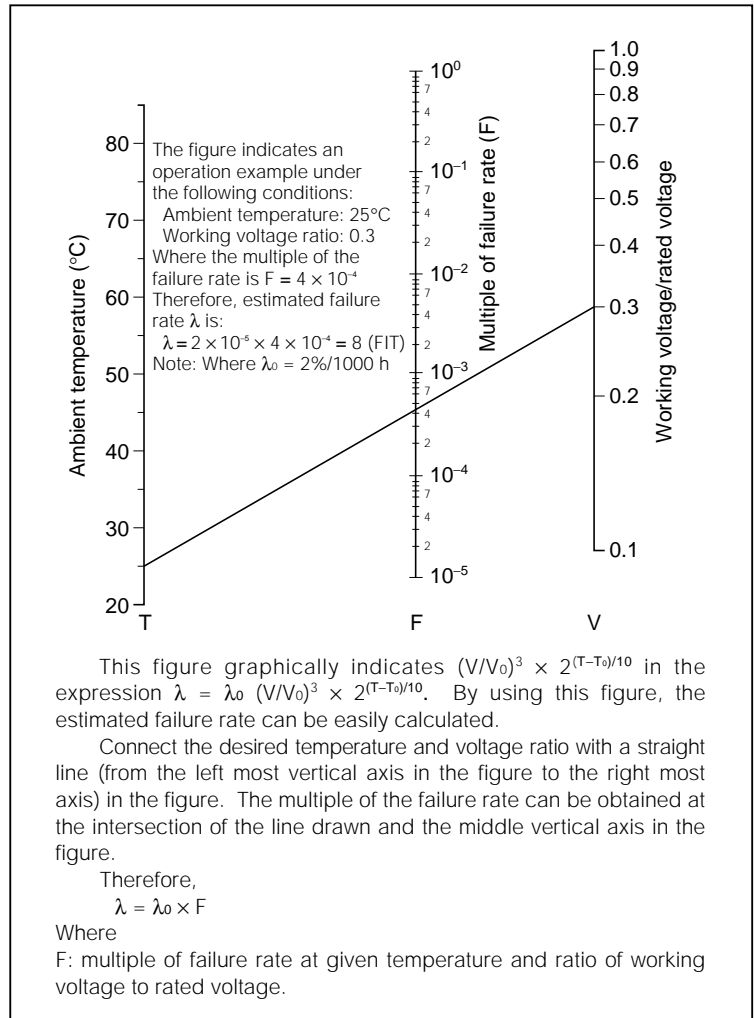

2. Ripple Voltage

- (1) Keep the sum of the DC voltage and peak value of the ripple voltage within the rated voltage.
- (2) If a ripple voltage is applied to the capacitor, the peak value of the ripple voltage must be kept within the values shown in the following figures:

Chips

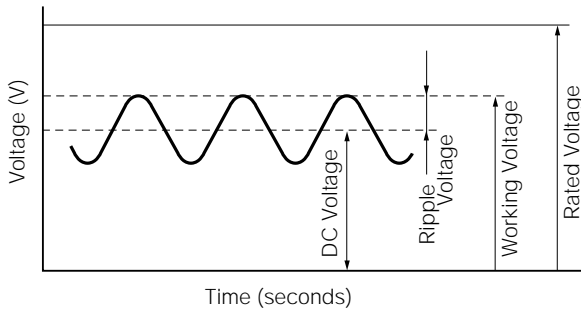
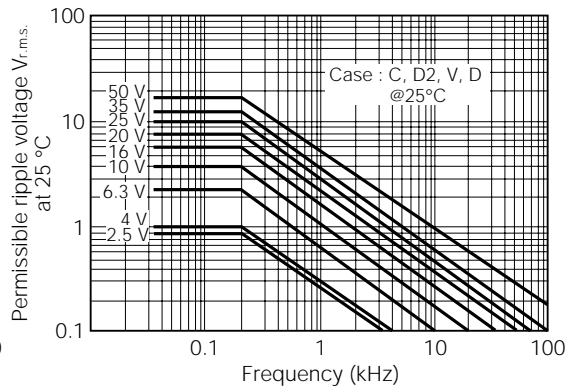
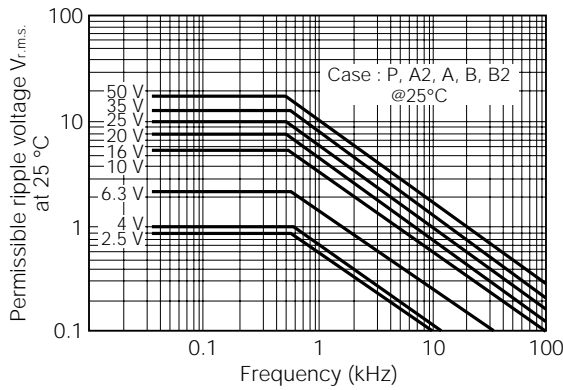

Calculate the permissible ripple voltage at a temperature higher than that specified in these figures by using the following expressions:

$$V_{r.m.s.} \text{ (at } 50^{\circ}\text{C)} = 0.7 \times V_{r.m.s.} \text{ (at } 25^{\circ}\text{C)}$$

$$V_{r.m.s.} \text{ (at } 85^{\circ}\text{C)} = 0.5 \times V_{r.m.s.} \text{ (at } 25^{\circ}\text{C)}$$

$$V_{r.m.s.} \text{ (at } 125^{\circ}\text{C)} = 0.3 \times V_{r.m.s.} \text{ (at } 25^{\circ}\text{C)}$$

- (3) Keep the negative peak value of the ripple voltage within the permissible reverse voltage value specified in the following section, Reverse Voltage.

3. Reverse Voltage

- Because the solid tantalum capacitor is of polar type, do not apply a reverse voltage to it. If reverse voltage cannot be avoided, it must be applied for a short time and must not exceed the following values:
 25°C 10% max. of rated voltage or 3 Vdc, whichever is smaller
 85°C 5% max. of rated voltage
 125°C 1% max. of rated voltage

- The figure on the right shows the relationship between current and reverse voltage.

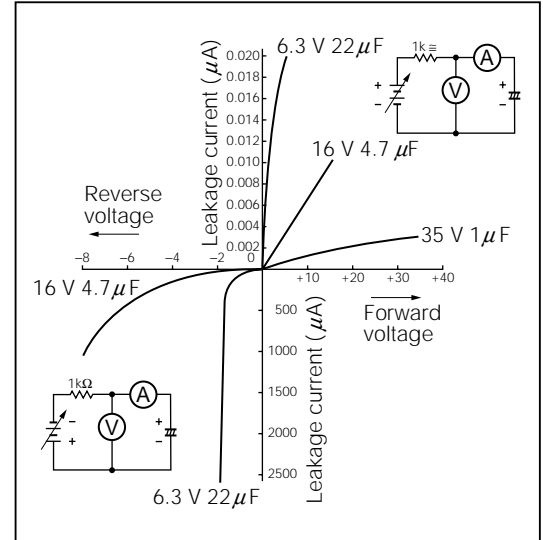

4. Applied Voltage

- For general applications, apply 70% or less of the rated voltage to the capacitor.
- When the capacitor is used in a power line or a low-impedance circuit, keep the applied voltage within 30% (50% max.) of the rated voltage to avoid the adverse influence of inrush current.
- Derated voltage at 85°C or more.
 When using a Chip-type capacitor at a temperature of 85°C or higher, calculate reduced voltage U_T from the following expression. Note, however, that the ambient temperature must not exceed 125°C.

The rated voltage ratio is as shown in the figure on the right.

$$U_T = V_0 \frac{U_R - U_C}{40} (T - 85)$$

Where

U_R : rated voltage (V)

U_C : derated voltage at 125°C

T: ambient temperature (°C)

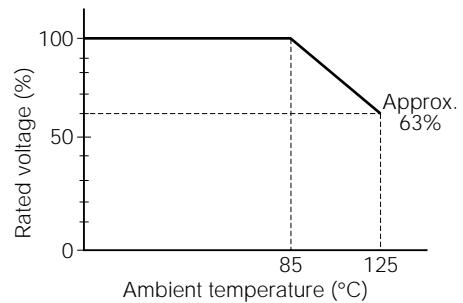

5. Current (Series Resistance)

As shown in the figure on the right, reliability is increased by inserting a series resistance of at least 3Ω/V into circuits where current flow is momentary (switching circuits, charge/discharge circuits, etc). If the capacitor is in a low-impedance circuit, the voltage applied to the capacitor should be less than 1/2 to 1/3 of the DC rated voltage.

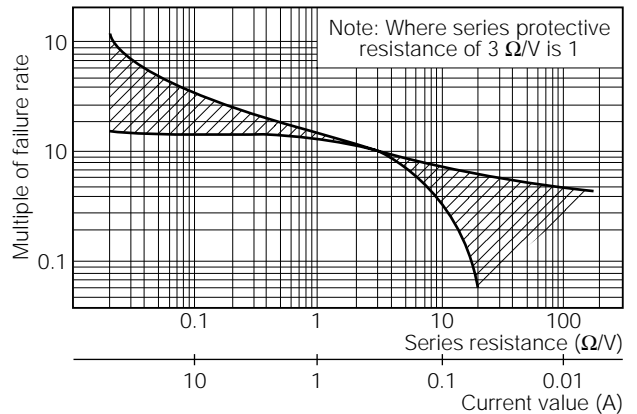

NOTES ON USING THE CHIP TANTALUM CAPACITORS, EXCLUDING NeoCapacitors

1. Mounting

(1) Direct Soldering

Keep the following points in mind when soldering the capacitor by means of jet soldering or dip soldering:

(a) Temporarily fixing resin

Because chip tantalum capacitors are larger and subject to more force than chip multilayer ceramic capacitors or chip resistors, more resin is required to temporarily secure the solid tantalum capacitors. However, if too much resin is used, the resin adhering to the patterns on a printed circuit board may adversely affect the solderability.

(b) Pattern design

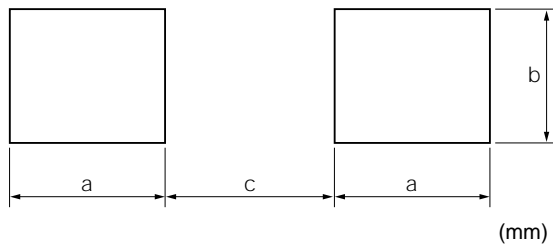

Case	a	b	c
P	2.2	1.4	0.7
A2 (U), A	2.9	1.7	1.2
B3 (W), B2 (S)	3.0	2.8	1.6
B	3.3	1.9	2.4
C	4.1	2.3	2.4
D2	5.4	2.9	2.4
D	5.2	2.9	3.7

The above dimensions are for reference only. If the capacitor is to be mounted by this method, and if the pattern is too small, the solderability may be degraded.

(c) Temperature and time

Keep the peak temperature and time within the following values:

Solder temperature 260°C max.

Time 5 seconds max. (10 seconds max. for SVH)

Whenever possible, perform preheating (at 150°C max.) for a smooth temperature profile. To maintain reliability, mount the capacitor at low temperature and in a short time.

(d) Component layout

If many types of chip components are mounted on a printed circuit board that is to be soldered by means of jet soldering, solderability may not be uniform over the entire board, depending on the layout and density of the components on the board (also take into consideration generation of flux gas).

(e) Flux

Use resin-based flux. Do not use flux with strong acidity.

(2) Reflow Soldering

Keep the following points in mind when soldering the capacitor in a soldering oven or with a hot plate:

(a) Pattern design (in accordance with IEC1188)

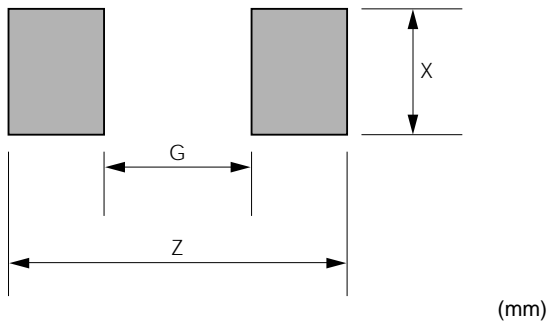

Case	G Max.	Z Min.	X Min.
J	0.7	2.5	1.0
P	0.5	2.6	1.2
A2 (U), A	1.1	3.8	1.5
B3 (W), B2 (S)	1.4	4.1	2.7
B	2.6	5.6	2.9
C	2.9	6.9	2.7
D2 (T)	2.7	6.7	2.9
D	4.1	8.2	2.9

The above dimensions are recommended. Note that if the pattern is too big, the component may not be mounted in place.

(b) Temperature and time

Keep the peak temperature and time within the following values:

- Solder temperature 260°C max.
- Time 10 seconds max.

Whenever possible, perform preheating (at 150°C max.) for a smooth temperature profile. To maintain reliability, mount the capacitor at low temperature and in a short time. The peak temperature and time shown above are applicable when the capacitor is to be soldered in a soldering oven or with a hot plate. When the capacitor is soldered by means of infrared reflow soldering, the internal temperature of the capacitor may rise beyond the surface temperature.

(3) Using a Soldering Iron

When soldering the capacitor with a soldering iron, controlling the temperature at the tip of the soldering iron is very difficult. However, it is recommended that the following temperature and time be observed to maintain the reliability of the capacitor:

- Iron temperature 300°C max.
- Time 3 seconds max.
- Iron power 30 W max.

2. Cleaning

Generally, several organic solvents are used for flux cleaning of an electronic component after soldering. Many cleaning methods, such as immersion cleaning, rinse cleaning, brush cleaning, shower cleaning, vapor cleaning, and ultrasonic cleaning, are available; cleaning methods may be used alone or two or more may be used in combination. The temperature of the organic solvent may vary from room temperature to several 10°C, depending on the desired effect. If cleaning is carried out with emphasis placed only on the cleaning effect, however, the marking on the electronic component cleaned may be erased, the appearance of the component may be damaged, and, in the worst case, the component may be functionally damaged. It is therefore recommended that the R series solid tantalum capacitor be cleaned under the following conditions:

Recommended conditions of flux cleaning

- (1) Cleaning solvent Chlorosen, isopropyl alcohol
- (2) Cleaning method Shower cleaning, rinse cleaning, vapor cleaning
- (3) Cleaning time 5 minutes max.

Note. Ultrasonic cleaning

This cleaning method is extremely effective for eliminating dust generated by mechanical processes, but may pose problems depending on the condition. An experiment conducted by NEC confirmed that the external terminals of the capacitor were cut when it was cleaned with some ultrasonic cleaning machines. The cause of this phenomenon is metal fatigue of the capacitor terminals due to ultrasonic cleaning. To prevent the terminal from being cut, decreasing the output power of the ultrasonic cleaning machine or shortening the cleaning time may be effective. However, it is difficult to specify the cleaning conditions because there are many factors involved, such as the conversion efficiency of the ultrasonic oscillator, transfer efficiency of the cleaning bath, difference in cleaning effect depending on the location in the cleaning bath, the size and quantity of the printed circuit boards to be cleaned, and the securing states of the components on the boards. It is therefore recommended that ultrasonic cleaning be avoided as much as possible.

If ultrasonic cleaning is essential, make sure through experiments that no abnormalities occur as a result of the cleaning. For further information, consult NEC.

3. Other

- (1) Do not subject the capacitor to excessive vibration and shock.
- (2) The solderability of the capacitor may be degraded by humidity. Store the capacitor at room temperature (–5 to +40°C) and humidity (40 to 60% RH).
- (3) Take care that no external force is applied to tape-packaged products (if the packaging material is deformed, the capacitor may not be automatically mounted by a chip mounter).

NOTES ON USING NeoCapacitors

1. Permissible Ripple Current

Permissible ripple current shall be derated as follows:

(1) Temperature Change

-55°C to +105°C: Rating value (p. 29, 30)

(2) Switching Frequency

1 MHz: Rating value (p. 29, 30)

500 kHz: 0.9 times rating value

100 kHz: 0.75 times rating value

2. Mounting

This capacitor is designed to be surface mounted by means of reflow soldering.

(The conditions under which the capacitor should be soldered with a soldering iron are explained in (2) Using a Soldering Iron. Because the capacitor is not designed to be soldered by means of laser beam soldering, VPS, or flow soldering, the conditions for these soldering methods are not explained in this document.)

(1) Reflow Soldering

Keep the following points in mind when soldering the capacitor in a soldering oven with a hot plate:

(a) Pattern design (in accordance with IEC1188)

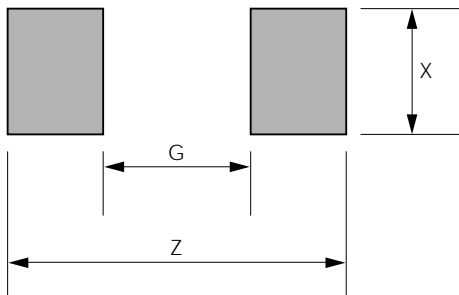

(mm)

Case	G Max.	Z Min.	X Min.
J	0.7	2.5	1.0
P	0.5	2.6	1.2
A2 (U), A	1.1	3.8	1.5
B3 (W), B2 (S)	1.4	4.1	2.7
C	2.9	6.9	2.7
V, D	4.1	8.2	2.9

The above dimensions are recommended. Note that if the pattern is too big, the component may not be mounted in place.

(b) Temperature and time

Keep the peak temperature and time within the following recommended conditions.

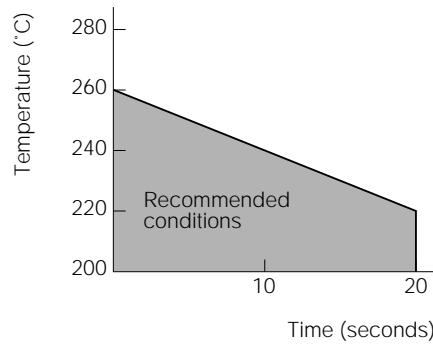

Whenever possible, perform preheating (at 150°C max.) for a smooth temperature profile. To maintain reliability, mount the capacitor at low temperature and in a short time. The peak temperature and time shown above are applicable when the capacitor is to be soldered in a soldering oven or with a hot plate. When the capacitor is soldered by means of infrared reflow soldering, the internal temperature of the capacitor may rise beyond the surface temperature.

(2) Using a Soldering Iron

When soldering the capacitor with a soldering iron, controlling the temperature at the tip of the soldering iron is very difficult. However, it is recommended that the following temperature and time be observed to maintain the reliability of the capacitor:

- Iron temperature ... 300°C max.
- Time 3 seconds max.
- Iron power 30 W max.

3. Cleaning

Generally, several organic solvents are used for flux cleaning of an electronic component after soldering. Many cleaning methods, such as immersion cleaning, rinse cleaning, brush cleaning, shower cleaning, vapor cleaning, and ultrasonic cleaning, are available, which may be used alone or in combination. The temperature of the organic solvent may vary from room temperature to several 10°C, depending on the desired effect. If cleaning is carried out with emphasis placed only on the cleaning effect, however, the marking on the electronic component cleaned may be erased, the appearance of the component may be damaged, and, in the worst case, the component may be functionally damaged. It is therefore recommended that the NeoCapacitor be cleaned under the following conditions:

[Recommended conditions of flux cleaning]

- (1) Cleaning solvent Isopropyl alcohol
- (2) Cleaning method Shower cleaning, rinse cleaning, vapor cleaning
- (3) Cleaning time 5 minutes max.

Note: Ultrasonic cleaning

This cleaning method is extremely effective for eliminating dust generated by mechanical processes, but may pose problems, depending on the condition. An experiment conducted by NEC confirmed that the external terminals of the capacitor were cut when it was cleaned with some ultrasonic cleaning machines. The cause of this phenomenon is metal fatigue of the capacitor terminals due to ultrasonic cleaning. To prevent the terminal from being cut, decreasing the output power of the ultrasonic cleaning machine or decreasing the cleaning time may be effective. However, it is difficult to specify safe cleaning conditions because there are many factors involved, such as the conversion efficiency of the ultrasonic oscillator, transfer efficiency of the cleaning bath, difference in cleaning effect depending on the location in the cleaning bath, the size and quantity of the printed circuit boards to be cleaned, and the securing states of the components on the boards. It is therefore recommended that ultrasonic cleaning be avoided as much as possible.

If ultrasonic cleaning is essential, make sure through experiments that no abnormalities occur as a result of the cleaning. For further information, contact NEC.

4. Derating

Apply appropriate voltage to the capacitors according to the failure rate estimation. It is recommended that the applied voltage be less than 80 % of the rated voltage.

5. Other

- (1) Do not subject the capacitor to excessive vibration and shock.
- (2) The solderability of the capacitor may be degraded by humidity. Store the capacitor at room temperature (–5 to +40°C) and humidity (40 to 60% RH).
- (3) Take care that no external force is applied to tape-packaged products (if the packaging material is deformed, the capacitor may not be automatically mounted by automatic insertion equipment).

The information in this document is based on documents issued in July, 2000 at the latest. The information is subject to change without notice. For actual design-in, refer to the latest of data sheets, etc., for the most up-to-date specifications of the device.

No part of this document may be copied or reproduced in any form or by any means without the prior written consent of NEC Corporation. NEC Corporation assumes no responsibility for any errors which may appear in this document.

NEC Corporation does not assume any liability for infringement of patents, copyrights, or other intellectual property rights of third parties by or arising from use of a device described herein or any other liability arising from use of such device. No license, either express, implied, or otherwise, is granted under any patents, copyrights, or other intellectual property rights of NEC Corporation or others.

While NEC Corporation has been making a continuous effort to enhance the reliability of its electronic components, the possibility of defects cannot be eliminated entirely. To minimize risks of damage or injury to persons or property arising from a defect in an NEC electronic component, customers must incorporate sufficient safety measures in its design, such as redundancy, fire-containment, and anti-failure features. NEC devices are classified into the following three quality grades:

"Standard," "Special," and "Specific." The Specific quality grade applies only to devices developed based on a customer-designated quality assurance program for a specific application. The recommended applications of a device depend on its quality grade, as indicated below. Customers must check the quality grade of each device before using it in a particular application.

Standard: Computers, office equipment, communications equipment, test and measurement equipment, audio and visual equipment, home electronic appliances, machine tools, personal electronic equipment, and industrial robots

Special: Transportation equipment (automobiles, trains, ships, etc.), traffic control systems, anti-disaster systems, anti-crime systems, safety equipment, and medical equipment (not specifically designed for life support)

Specific: Aircraft, aerospace equipment, submersible repeaters, nuclear reactor control systems, life support systems, or medical equipment for life support, etc.

The quality grade of NEC devices is "Standard" unless otherwise specified in NEC's data sheets or data books. If customers intend to use NEC devices for applications other than those specified for Standard quality grade, they should contact an NEC sales representative in advance.

(Note)

- (1) "NEC" as used in this statement means NEC Corporation and also includes its majority-owned subsidiaries.
- (2) "NEC electronic component products" means any electronic component product developed or manufactured by or for NEC (as defined above).

DE0102

For further information, please contact:

NEC Corporation

NEC Electron Devices
7-1, Shiba 5-chome, Minato-ku
Tokyo 108-8001, Japan
Tel: 03-3798-9583
Fax: 03-3798-6149

[North & South America]

**NEC Electronics Inc.
Electron Components**
2880 Scott Boulevard
Santa Clara, CA 95052-8062, USA
Tel: 408-588-6000
Fax: 408-588-6130

(Regional Sales Offices)

Central Region
801 Warrenville Road,
Suite 65
Lisle, IL 60532, USA
Tel: 630-241-3040
Fax: 630-241-3057

Eastern Region

Two Central Street,
Suite 204
Middleton, MA 01949, USA
Tel: 978-762-7400
Fax: 978-762-7444

Western Region

Western Region
6033 W. Century Blvd.,
Suite 840
Los Angeles, CA 90045, USA
Tel: 310-645-0985
Fax: 310-645-3149

NEC do Brasil S.A.

Div. Componentes Electronicos
Rodovia Presidente Dutra, Km 218
CEP 07210-902-Jd.
Cumbica-Guarulhos-SP, Brasil
Tel: 011-6462-6810
Fax: 011-6462-6829

[Europe]

NEC Electronics (Germany) GmbH
Kanzlerstr. 2,
40472 D_esseldorf
Germany
Tel: 0211-650302
Fax: 0211-6503490

NEC Electronics (Benelux).

Boschdijk 187a
5612 HB Eindhoven
Netherlands
Tel: 040-2445845
Fax: 040-2444580

NEC Electronics (Scandinavia)

P.O. Box 134
S-18322 Taeby, Sweden
Tel: 08-6380820
Fax: 08-6380388

NEC Electronics (France) S.A.

9, rue Paul Dautier-BP187
78142 Velizy-Villacoublay Cedex
France
Tel: 01-30 67 58 00
Fax: 01-30 67 58 99

Madrid Office

Juan Esplandiu, 15
E-28007 Madrid, Spain
Tel: 091-504-2787
Fax: 091-504-2860

NEC Electronics Italiana s.r.l.

Via Fabio Filzi 25/A
20124 Milano, Italy
Tel: 02-667541
Fax: 02-66754299

NEC Electronics (UK) Limited

Cygnus House, Sunrise Parkway,
Milton Keynes, MK 14 6NP, U.K.
Tel: 01908-691-133
Fax: 01908-670-290

Dublin Office

34/35, South William Street
Dublin 2, Ireland
Tel: 01-6794200
Fax: 01-6794081

[Asia & Oceania]

NEC Electronics Hong Kong Limited
12/F., Cityplaza 4, 12
Taikoo Wan Road, Hong Kong
Tel: 2886-9318
Fax: 2886-9022, 2886-9044

Seoul Branch

10F, ILSONG Bldg., 157-37
Samsung-Dong, Kangnam-Ku,
Seoul, the Republic of Korea
Tel: 02-528-0303
Fax: 02-528-4411

Shen-Zhen Office

Room 03-05, 51/F, Office Tower,
Shun Hing Square 5002 Shen Nan Dong Road,
Shenzhen, China
Tel: 755-246-1092/1976
Fax: 775-246-1786

Australia Representative Office

303-313 Burwood Highway
Burwood East, Victoria 3151, Australia
Tel: 03-98878012
Fax: 03-98878014

NEC Electronics Taiwan Ltd.

7F, NO. 363 Fu Shing North Road
Taipei, Taiwan, R.O.C.
Tel: 02-2719-2377
Fax: 02-2719-5951/5936

NEC Electronics Singapore Pte. Ltd.

101 Thomson Road #04-01/05
United Square, Singapore 307591
Tel: 253-8311
Fax: 250-3583

AE0203